

RITE® SERIES 211 SINGLE DOOR FLANGED TYPE SWING CHECK VALVE INTEGRAL HARD SEAT



OVERVIEW

The Rite® Series 211 flanged combination swing check valves are flow activated and Rite® sized. The Rite® Series Check Valve inlet ports and disc have been shape optimized to achieve a fully open position at low flow rates (3 ft/s on average).

SPECIFICATIONS

Size Range	NPS 2" to 42" 50mm to 1050mm
Temperature Range	Cryogenic to High Temperature (Pending Materials Selected)
Operating Pressure	ASME (150, 300, 600, 900, 1500) DIN (PN10, 16, 25, 40, 64, 100, 150, 250)
Body Style	One-Piece Flanged Body Integral Type
Leakage Rate	API 598

APPLICATIONS

- > Chemical Processing
- > Electrolysis
- > Facilities/Skid
- > HVAC
- > Marine
- > Nuclear
- > Oil Transport
- > Petrochemical
- > Power Generation
- > Refrigeration
- > Storage & Transport
- > Tank Trucks
- > Water

MEDIA

- > Acids
- > Alkalis
- > Corrosive Chemicals
- > Dry Chlorine (Gas or Liquid)
- > Gases
- > Hydrogen
- > Oxygen
- > Water

DESIGN FEATURES

The Series 211 hard seated check valves offer:

SINGLE DOOR DESIGN:

Below numbered list can be referenced on various figures throughout document

- 1 Combination design utilizing both gravity + spring makes the valve easy to open/close, reducing water hammer.
- 2 Limited movement of internal parts during operation extends service life.
- 3 Elliptical inlet shape designed to accelerate line media through the valve.
- 4 Optimal diameter for high flow capacity.
- 5 Short face to face, reducing weight and space between flanges.
- 6 Low cracking pressure design.
- 7 Quick response time (ideal for process lines with varying flows & control valves).
- 8 Customizable modular design, allows for adding optional special accessories to meet customer application requirements.
- 9 Cost & energy efficiency, requiring only one set of flange studs which span the valve, reducing in-service vibration.
- 10 Integral design reduces leak path enhancing life expectancy.

Figure 01: Integral Hard Seat Cutaway Front View.

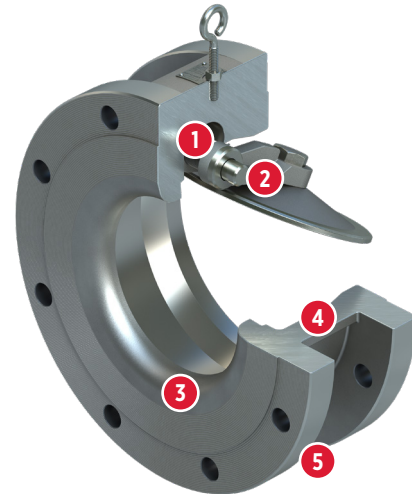
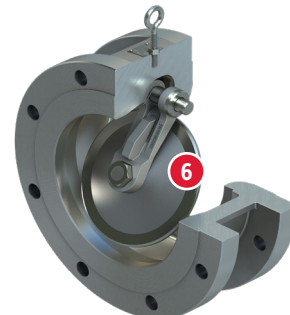

Figure 02: Integral Hard Seat Cutaway Rear View.



RITE® SERIES 211
SINGLE DOOR FLANGED TYPE SWING CHECK VALVE
INTEGRAL HARD SEAT



DESIGN STANDARDS

Valve Design	API 594
Accessories Available	H100, SA01, SA1, SA2, SA3, SA4, SA4A, SA6, SA7, SA10, SA16, SA40, SA40A, SA50, SA54, etc.
Testing Standard	ASME B16.34, API 598
Face-to-Face	API 594

CERTIFICATIONS AND APPROVALS

Certifications	API-6FD CE/PED CRN
Approvals	NSF-61

Additional information is available in the Bray Rite® Ltd. Technical Sales Manual.

Figure 03: Integral Hard Seat Exploded View.

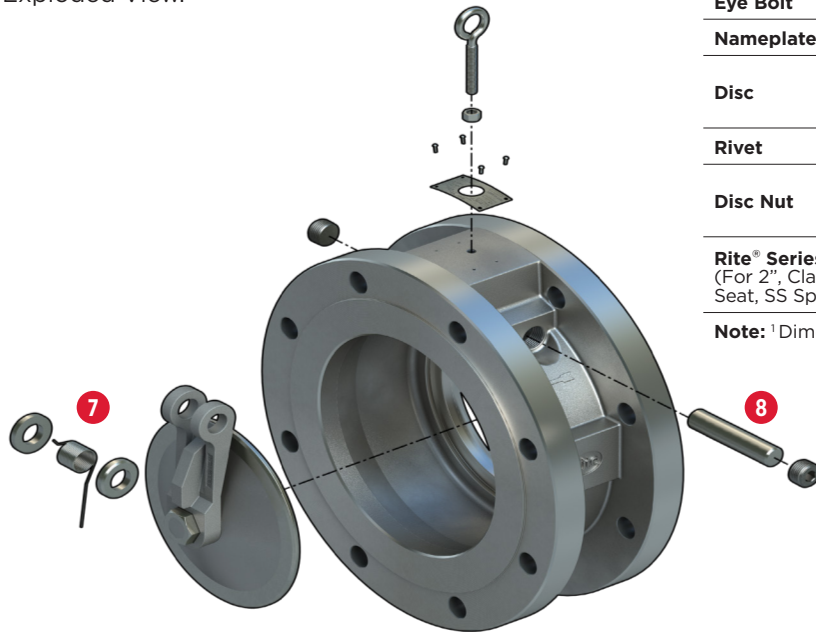
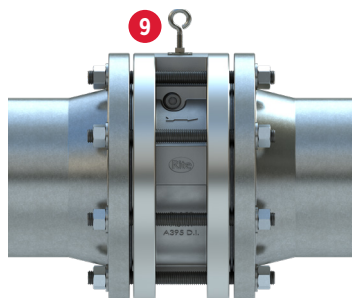

Figure 04: Integral Hard Seat In-Pipe View.



MATERIAL OPTIONS¹

Body Material determines whether design is integral type, or seat ring type. See below chart:

Body	Stainless Steel (ASTM A351 CF8M) Exotic Alloys
Hinge	Stainless Steel (ASTM A351 CF8M) Matches body material on exotic materials
Seat (Integral)	Matches body material, Stellite overlay optional
Spring	Valve size: <12": Stainless Steel (ASTM A313 316) standard duty Valve size: ≥14"+: Stainless Steel (ASTM 313 17-7 PH) Inconel (X750) internal torsion spring on exotic body materials
Spacer	Stainless Steel (ASTM A479 316), PTFE optional
Pin	Stainless Steel (ASTM A479 316) Matches body material on exotic materials
Plug	Stainless Steel (SS 316) Matches body material on exotic materials
Lock Nut	Steel Zinc Plated
Eye Bolt	Steel Zinc Plated
Nameplate	Stainless Steel (SS 316)
Disc	Stainless Steel (ASTM A351 CF8M) Matches body material on exotic materials
Rivet	Steel Zinc Plated
Disc Nut	Stainless Steel (ASTM F594 316) Matches body material on exotic materials

Rite® Series Check Valve integral type part number: V0215XMZ211 (For 2", Class 150, Stainless Steel ASTM A351 CF8M Body, Metal Seat, SS Spacer, Series 211)

Note: ¹ Dimensions available in ASME and DIN sizes.

Figure 05: Integral Hard Seat Close-Up Cutaway Views.

