

---

**TRI LOK®-Cx**

# **TRIPLE OFFSET BUTTERFLY VALVE**

TECHNICAL SALES MANUAL

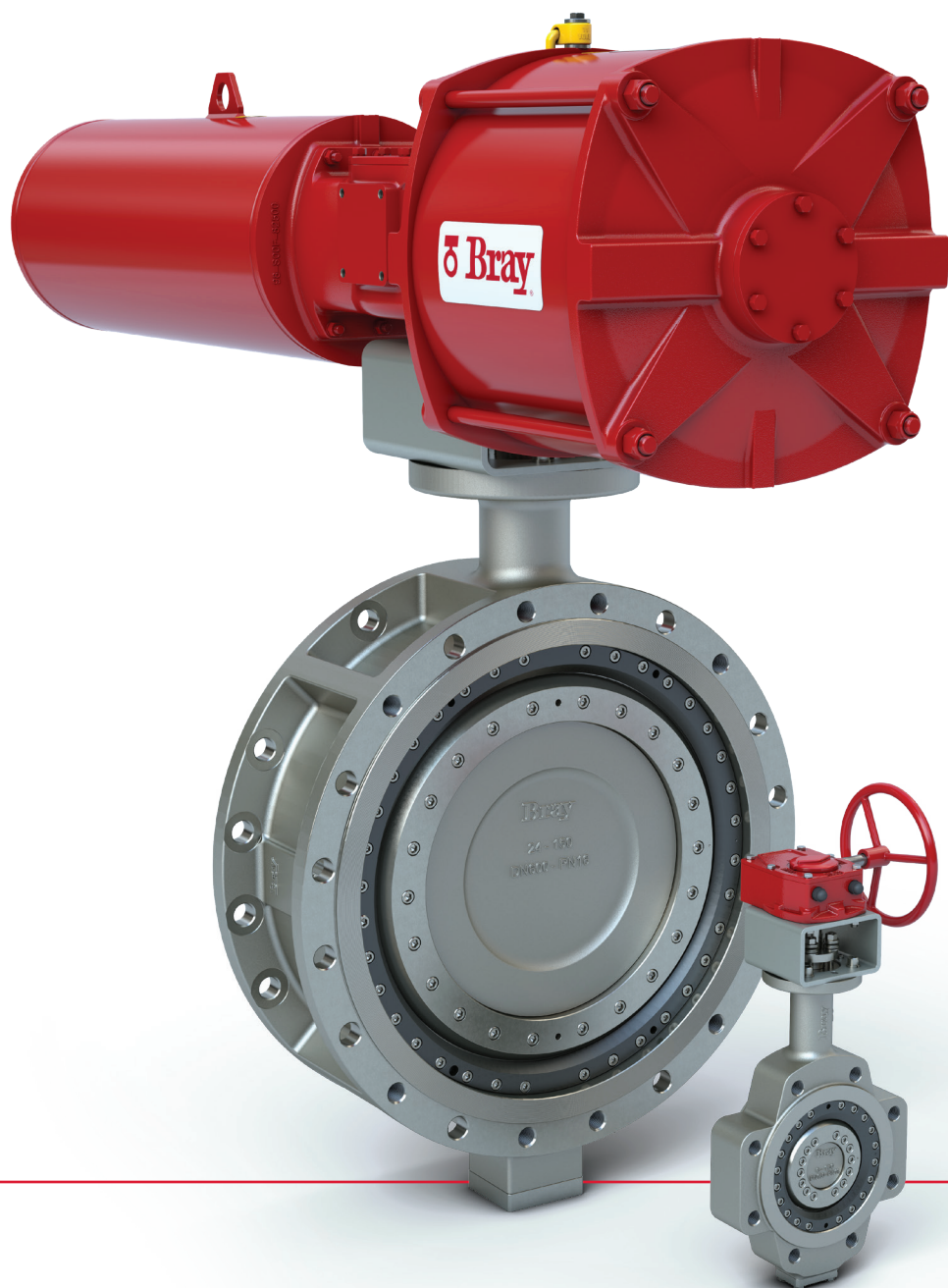

**Bray®**

[BRAY.COM](http://BRAY.COM)

THE HIGH PERFORMANCE COMPANY

OVERVIEW . . . . .	3
CHEMICAL/PETROCHEMICAL SOLUTIONS. . . . .	4
FEATURES & BENEFITS . . . . .	5
TRIPLE OFFSET DESIGN . . . . .	6
DESIGN FEATURES . . . . .	7
OPTIONS & SPECIAL APPLICATIONS . . . . .	8
VALVE & OPERATOR ORIENTATION. . . . .	9
VALVE SELECTION. . . . .	10
MATERIALS OF CONSTRUCTION – PARTS CALLOUT . . . . .	11
MATERIALS OF CONSTRUCTION – PARTS LIST. . . . .	12
PRESSURE/TEMPERATURE RATINGS . . . . .	13
DIMENSIONS & WEIGHTS. . . . .	14
VALVE SIZING COEFFICIENTS . . . . .	20
FLANGE TO VALVE BOLTING DATA . . . . .	21

## OVERVIEW

### TRIPLE OFFSET BUTTERFLY VALVE

Tri Lok®-Cx is the premier isolation valve for operation in light vacuum to high-pressure applications. The non-rubbing, metal-to-metal seal delivers zero-leakage bidirectional shutoff with minimal torque, and is certified firesafe. Compared to gate, globe, or ball valves of the same size and pressure class, Tri Lok®-Cx provides space and weight savings, while minimizing installation and maintenance costs.

### APPLICATIONS

- > Steam distribution
- > Industrial gases
- > Tank farms and storage
- > Hydrocarbon processing
- > Petrochemical processing
- > Chemical processing
- > Hydrogen service
- > Reactor isolation
- > Loading and unloading
- > Safety related applications
- > Flare systems
- > Emergency shutdown (ESD) applications

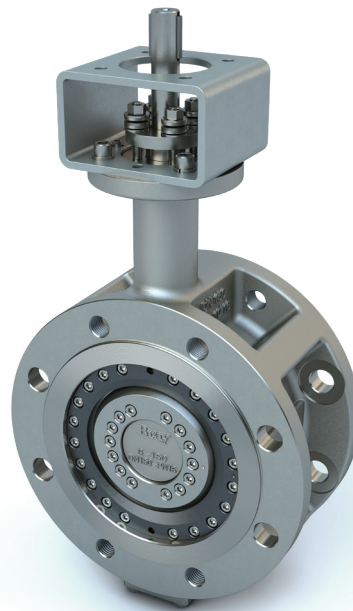

### SPECIFICATIONS

<b>Size Range<sup>1</sup></b>	DN 80 to 600
<b>Temperature Range<sup>2</sup></b>	-60°C to 400°C
<b>Pressure Rating</b>	PN 10   PN 25   PN 40
<b>Body Style</b>	Lug   Double Flanged
<b>Tightness Test<sup>3</sup></b>	Zero-leakage EN 12266 Rate A

#### NOTES

- 1 Larger sizes available on request.
- 2 Other temperatures available on request.
- 3 All valves tested bidirectionally.

### DESIGN STANDARDS

<b>Valve Design</b>	EN 12516-1   EN 12569   EN 593
<b>Material Standard</b>	EN 16668   AD2000 W0
<b>Marking</b>	EN 19   DIN EN IEC 61406   DIN 91406
<b>Top Flange</b>	ISO 5211
<b>Flange Drilling</b>	EN 1092-1
<b>Face-to-Face</b>	EN 558
<b>Testing Standard</b>	EN 12266-1 & 2   NE 167
<b>AutoID/ID Link</b>	DIN 91406/IEC 61406

### MATERIAL OPTIONS<sup>1</sup>

<b>Body</b>	Carbon Steel Stainless Steel
<b>Disc</b>	Carbon Steel Stainless Steel
<b>Seat</b>	Stainless Steel (Hardened)
<b>Seal Ring</b>	Laminated: Duplex Stainless Steel + Graphite Solid Seal: Duplex Stainless Steel
<b>Stem</b>	410 Stainless Steel XM-19 (Nitronic® 50)

#### NOTE

- 1 Other materials available upon request.

### CERTIFICATIONS & APPROVALS

<b>Certifications</b>	CE: PED 2014/68/EU SIL 3 capable UKCA
<b>Fire Test</b>	ISO 10497
<b>Fugitive Emissions</b>	ISO 15848-1 TA-Luft 2021
<b>Approvals</b>	ATEX 2014/34/EU

Tri Lok®-Cx valves provide a wide range of solutions across the chemical sector.



#### **REFINERIES**

Used to control the flow of various fluids, including crude oil, refined petroleum products, and intermediate chemicals.

- > Commonly used in process units such as distillation columns, reactors, and fractionation towers.

#### **PETROCHEMICAL PLANTS**

Crucial in the handling of a wide range of chemicals, including acids, solvents, and hydrocarbons.

- > Commonly used in processes such as polymerization, cracking, alkylation, and catalytic reforming.

#### **GAS PROCESSING PLANTS**

Vital in natural gas processing plants for controlling the flow of gases, such as methane, ethane, propane, and butane.

- > Commonly used in processes like gas separation, dehydration, and compression.

#### **CHEMICAL REACTORS**

- > Regulates the flow of reactants, catalysts, and heat transfer fluids.

#### **TANK FARMS AND STORAGE TERMINALS**

- > Controls the flow of liquids and gases during storage, loading, and unloading operations.

#### **HIGH-TEMPERATURE APPLICATIONS**

Suitable for high-temperature processes encountered in the chemical and petrochemical industry.

- > Handles extreme temperatures and maintains tight shut-off under challenging conditions.

#### **FLARE SYSTEMS**

Flare systems are an integral part of petrochemical plants for safely disposing of excess gases through controlled burning.

- > Isolates and controls the flow of gases into the flare system during normal operation or emergency situations.

#### **EMERGENCY SHUT-DOWN (ESD) SYSTEMS**

- > Integrated into emergency shut-down systems to rapidly isolate sections of a process plant during emergencies or critical events.



## FEATURES & BENEFITS

The Tri Lok®-Cx features a fully adjustable, field replaceable seat and seal system that extends overall service life, minimizes downtime, and reduces the need for costly offsite repairs or total valve replacement.

- 1 SEAT:** The hardened seat reduces the risk of galling, offering superior performance and durability.
- 2 SEAL RING:** Offers a flexible design and wide range of materials to provide torque-loaded sealing with zero-leakage.
- 3 LIVE LOADED STEM PACKING:** Fully adjustable, field replaceable stem seal system is certified to international fugitive emission standards.
- 4 SPLINED DISC-TO-STEM CONNECTION:** Strong, reliable connection allows for axial movement, prevents misalignment, minimizes hysteresis, and eliminates external connections.
- 5 ROBUST BLOWOUT-PROOF STEM:** The one-piece stem features a blowout prevention ring located above the packing box, outside the pressure boundary. The stem is also mechanically retained for additional protection.
- 6 INDEXED STEM:** Provides positive visual indication of disc/seal ring position after installation.
- 7 STEM BEARINGS:** Elongated to provide maximum stem support, and hardened to reduce wear.
- 8 BEARING SEALS:** Minimize ingress of media into the journal.
- 9 DIGITAL TAG:** Each valve is uniquely and easily identifiable by simply scanning the QR Code on the product identification tag in accordance to IEC 61406.

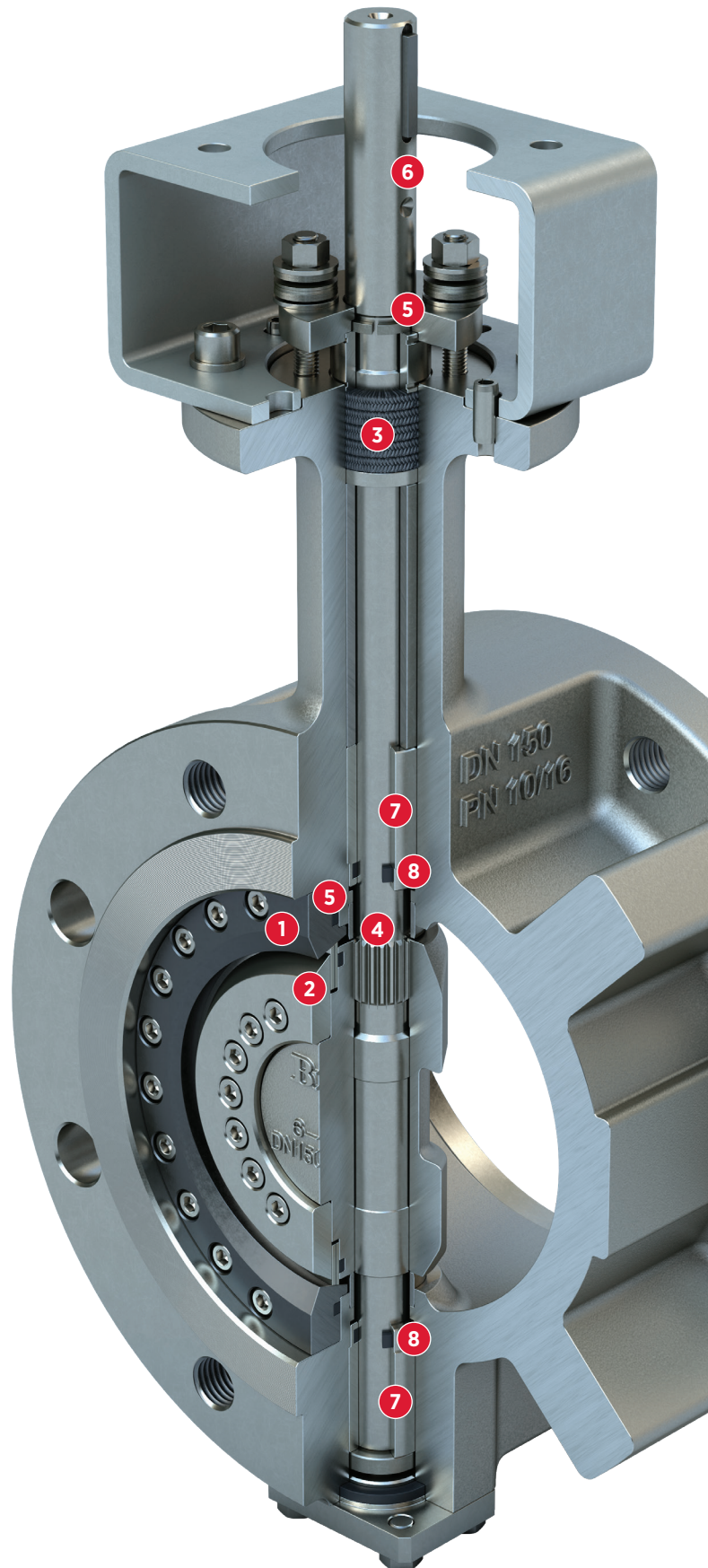

### BLOWOUT-PROOF STEM

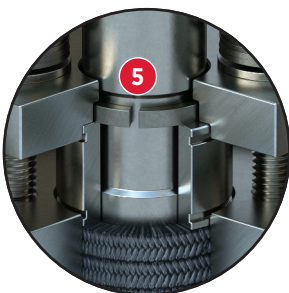

**Blowout Prevention Ring**  
Located outside pressure boundary.

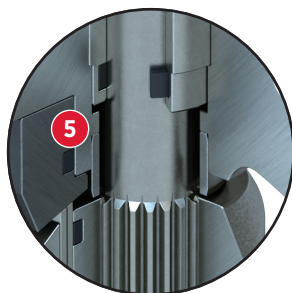

**Mechanical Retention**  
For additional blowout protection.

# TRIPLE OFFSET DESIGN

## TRIPLE OFFSET GEOMETRY

When a tight seal is required, a triple offset valve can be the right solution. As the name implies, three separate offsets are designed into the valve.

- 1 OFFSET 1**  
The center line of the stem is offset from the seat sealing surfaces.
- 2 OFFSET 2**  
The location of the stem is offset from the center line of the valve bore.
- 3 OFFSET 3**  
The sealing axis cone angle is offset from the center line of the valve bore.

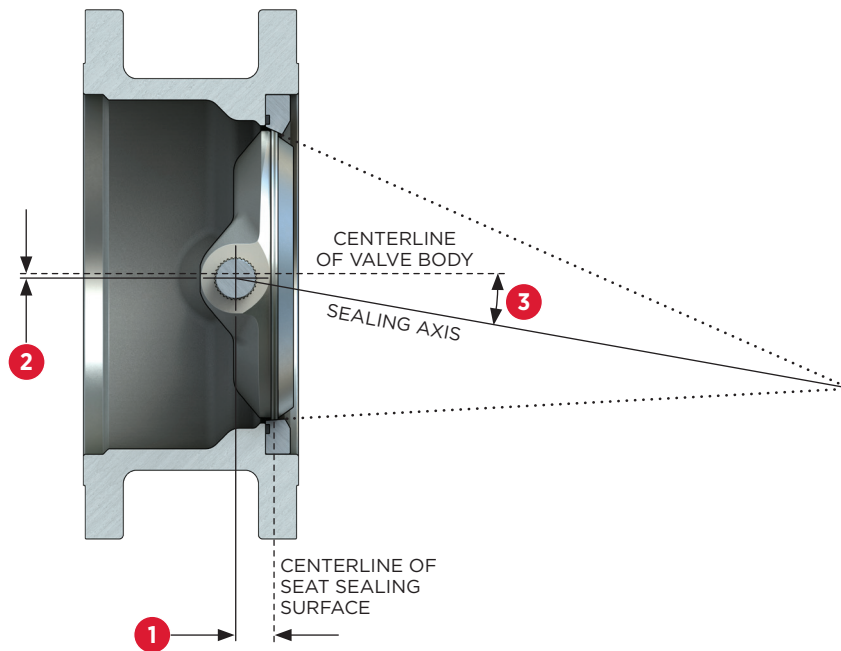

## BENEFITS

- > Unique geometry imparts a camming action which eliminates seat/seal rubbing and wear, and compensates for extreme temperatures.
- > Torque is applied in order to create a bidirectional, zero leak, metal-to-metal seal.
- > Preserves metal-to-metal sealing integrity over the lifecycle of the valve.

## METAL-TO-METAL SEALING PRINCIPLE

The Tri Lok®-Cx non-rubbing, metal-to-metal sealing system is inherently Fire-Safe (certified to ISO 10497) while meeting zero-leakage requirements for critical applications.

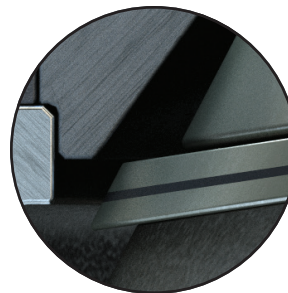

**Approaching Seat**  
Seal ring makes no contact prior to seating.

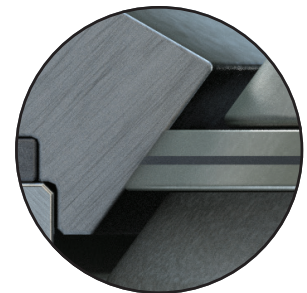

**Fully Seated**  
When seated, seal ring is radially compressed into seat through torque loading.

## DESIGN FEATURES

### ENHANCED SEAT HARDNESS

Superior hardness difference between seat & seal provides high reliability and extended service life.

#### Elimination of Galling

- > Difference in hardness is important and necessary to avoid adhesive wear (galling) to both the seat and seal ring.

#### Corrosion Resistance

- > Enhanced hardening maintains a high corrosion resistance as an advantage over cobalt-based deposition in most corrosive environments.

#### Wear Resistance

- > Resistant to abrasion and erosion caused by flue gas particles, sand, molecular sieve desiccant, silica, ceramic particles, or dust.

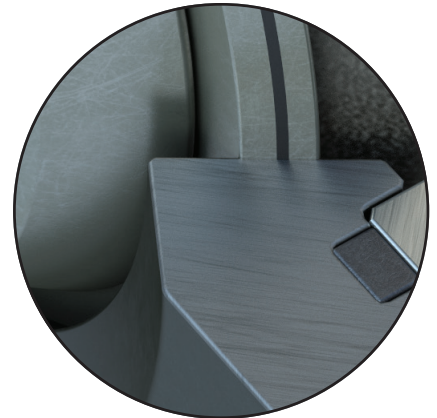

### INDEPENDENTLY REPLACEABLE SEAT & SEAL

#### Designed for Repairability

Fully-replaceable seat and seal system provides major benefits over other manufacturers, minimizing downtime without the need for costly offsite repairs or total valve replacement.

- > Seats and seals are independently replaceable.
- > Valves can be serviced on-site with no welding, machining, or special tools.
- > Hardened seats provide superior hardness and durability.
- > Wide choice of available seat and seal ring materials for tough applications.
- > Maintenance downtime and costs are substantially reduced, extending the overall service life of the valves.



### SPLINED DISC-TO-STEM CONNECTION

#### Strongest & Most Reliable Connection

Tri Lok®-Cx triple offset valves have a superior, splined disc-to-stem connection which eliminates external pins or keys, prevents typical misalignment problems of rigidly attached discs and stems, offers maximum strength, and minimizes hysteresis.

- > Eliminates hysteresis throughout operating range.
- > Superior performance in control applications.
- > Temperature changes do not affect valve performance or connection rigidity.
- > Easy to disassemble.
- > No concentrated stress or shear points.

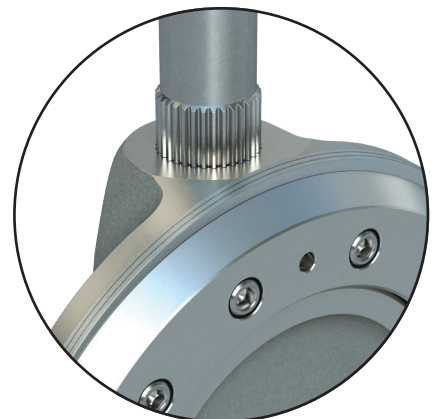

## OPTIONS & SPECIAL APPLICATIONS

### OPTIONS

#### Solid Seal

- > Direct replacement for laminated seal.
- > Tested to meet or exceed the requirements of EN 12266-1.
- > Available in multiple materials: Duplex Stainless Steel, Inconel®, or XM-19.
- > Ideal for applications which include particulates.
- > Suitable for applications incompatible with hydrocarbons or graphite.

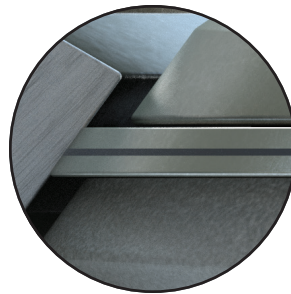

Laminated Seal Ring

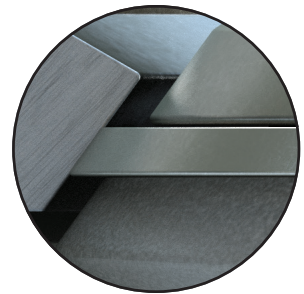

Solid Seal Ring

#### Lantern Rings

- > Additional ring in packing arrangement with threaded port in body neck.
- > Allows grease or sealant injection into stem packing area.
- > Ideal for applications where eliminating fugitive emissions is critical.

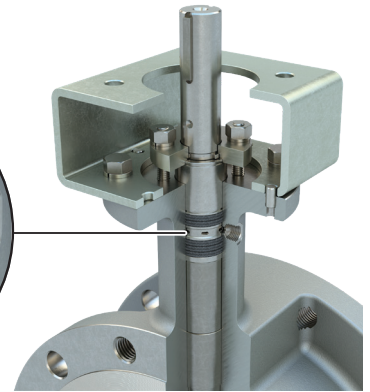
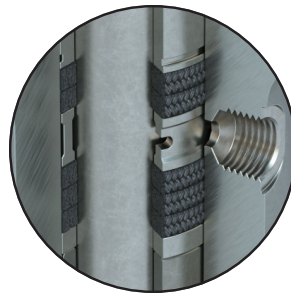

### SPECIAL APPLICATIONS

Bray can provide engineered solutions for your most critical applications.

#### Steam Jackets

- > Welded or bolt-on construction, available upon request.
- > Used for applications where flow media can polymerize or adhere to surfaces cooler than process.



Steam Jackets

#### Unique Automation Options

- > Tri Lok®-Cx valves are automation ready and fully compatible with Bray's broad actuation and accessory portfolio.

#### Emergency Shutdown

- > Quick acting closure.
- > Automated with Series 98 scotch yoke pneumatic actuator.
- > Optional hydraulic dampener.

#### Double Block and Bleed Configuration

- > Constructed from two triple offset valves, a spool piece, and a drain ball valve.
- > Provides ability to monitor pressure in cavity between two triple offset valves to ensure safe downstream work.

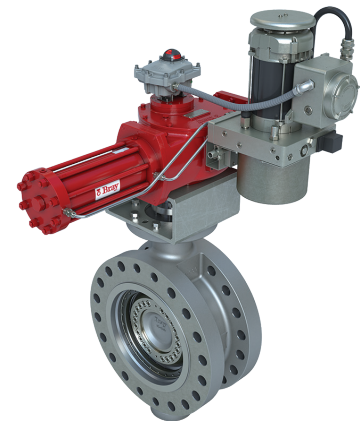

Tri Lok®-Cx shown with Series 98EH actuator with electro-hydraulic power pack.

# VALVE & OPERATOR ORIENTATION

## VALVE ORIENTATION

A horizontal stem orientation is beneficial for reducing the possibility of solid media particles depositing in the bearing areas.

Whenever possible, the valve should be installed with the stem in the horizontal position. For installations where this is not possible, the stem should be declined from vertical (as shown).

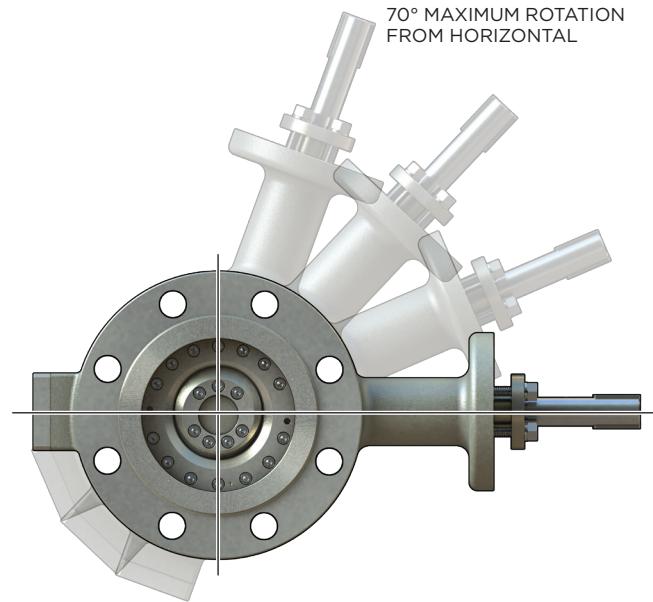

## ACTUATOR ORIENTATION

**2H**  
Standard

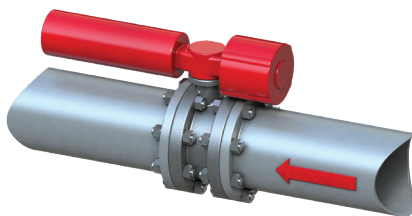

**5H**

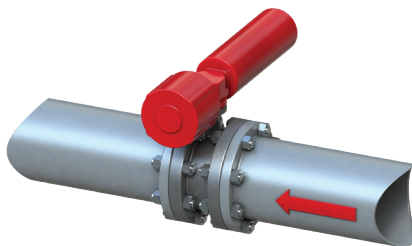

**9H**

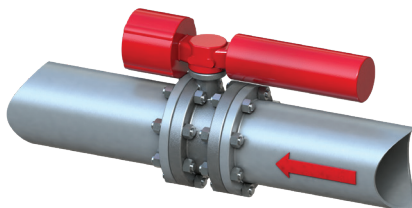

**13H**

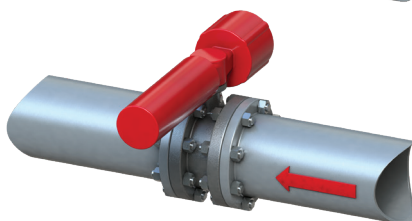

## GEAR ORIENTATION

**A**

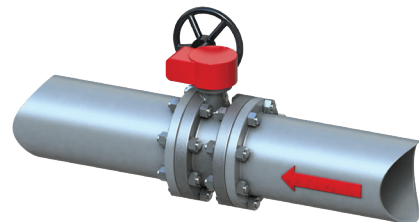

**B**

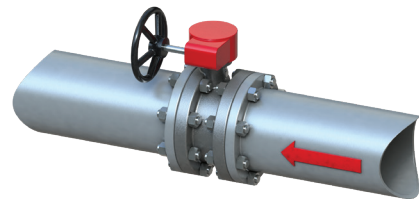

**C**  
Standard

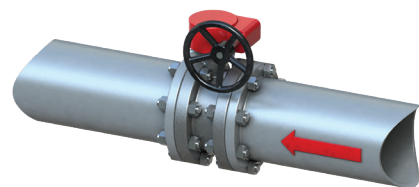

**D**

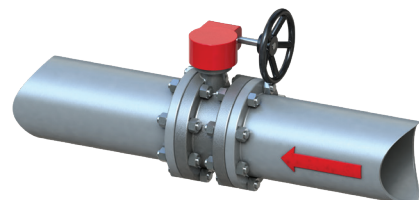

## VALVE PART NUMBERING SYSTEM

Select one code from each category to build a complete valve order number.

**XX-MXXX-110XX-XXX**

SERIES X		SERIES X		SIZE MXXX		BASE NUMBER 110XX		TRIM XXX			
Code	Body Style	Code	PN	Code	DN	Code	Description	Code	Item	Material <sup>1</sup>	
L	Lug	A	10	M080	80	110KE	Bare Stem Valve, PN flange drilling	C96	Body	Carbon Steel (EN 1.0619)	
F	Double Flanged	C	25	M100	100				Seat	Stainless Steel (EN 1.4401) + Nitride	
		D	40	M150	150				Disc	Carbon Steel (EN 1.0619)	
				M200	200				Seal Ring	Duplex Stainless Steel (EN 1.4462) + Graphite	
				M250	250				Stem	410 Stainless Steel	
				M300	300				RAM	Body	Stainless Steel (EN 1.4408)
				M350	350					Seat	Stainless Steel (EN 1.4401) + Nitride
				M400	400					Disc	Stainless Steel (EN 1.4408)
				M500	500	Seal Ring	Duplex Stainless Steel (EN 1.4462) + Graphite				
				M600	600		Stem	XM-19 (Nitronic 50)			

### NOTES:

- 1 Other materials are available on request.  
Please contact Bray for additional information.

### EXAMPLE

#### LC-M200-110KE-C96

- > Lug Body
- > PN 25
- > DN 200
- > Trim C96

PARTS CALLOUT

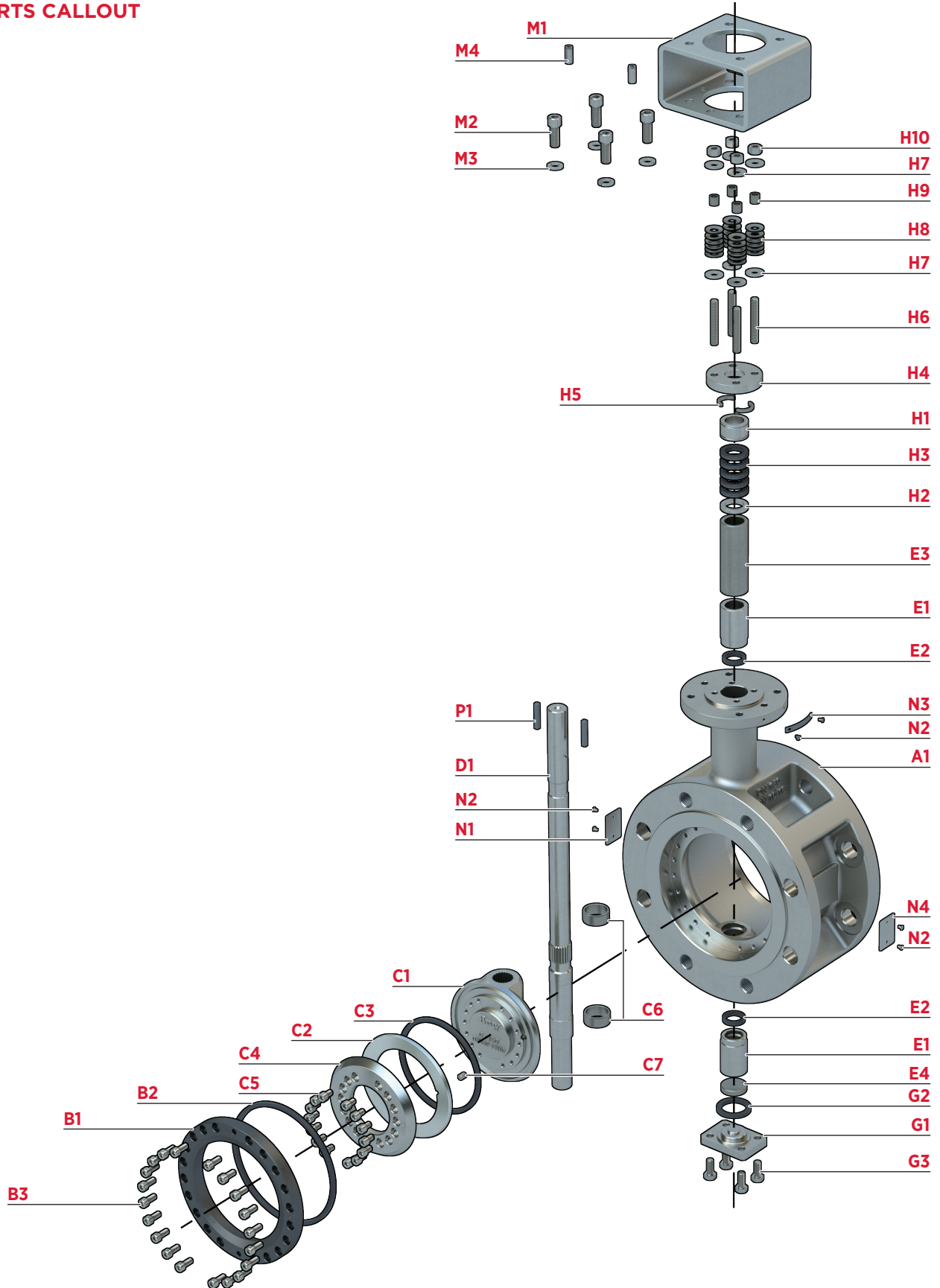

**PARTS LIST AND MATERIAL SPECIFICATIONS**

ITEM	DESCRIPTION	MATERIAL OPTIONS
<b>A1</b>	Body	Carbon Steel (EN 1.0619) Stainless Steel (EN 1.4408)
<b>B1</b>	Seat	Stainless Steel (1.4401) + Nitride
<b>B2</b>	Seat Gasket	Graphite
<b>B3</b>	Seat Cap Screw	A4-70
<b>C1</b>	Disc	Carbon Steel (EN 1.0619) Stainless Steel (EN 1.4408)
<b>C2</b>	Seal Ring	Duplex Stainless Steel (1.4462) + Graphite
<b>C3</b>	Seal Ring Gasket	Graphite
<b>C4</b>	Seal Ring Retainer	Carbon Steel (EN 1.0619) Stainless Steel (EN 1.4408)
<b>C5</b>	Seal Ring Retainer Cap Screw	A4-70
<b>C6</b>	Disc Spacer	Stainless Steel
<b>C7</b>	Seal Ring Pin	Stainless Steel
<b>D1</b>	Stem	F6A CL.3/ 410 Stainless Steel XM-19 (Nitronic 50)
<b>E1</b>	Stem Bearing	Stainless Steel + Nitride
<b>E2</b>	Bearing Protector Gasket	Graphite
<b>E3</b>	Bearing Spacer	Stainless Steel
<b>E4</b>	Lower Bearing Spacer	Stainless Steel + Nitride
<b>G1</b>	Bottom Plate	Carbon Steel (EN 1.0619) Stainless Steel (EN 1.4408)
<b>G2</b>	Bottom Plate Gasket	Graphite
<b>G3</b>	Bottom Plate Cap Screw	A4-70
<b>H1</b>	Packing Gland Ring	Stainless Steel
<b>H2</b>	Thrust Washer	Stainless Steel + Nitride
<b>H3</b>	Stem Packing	Graphite / PTFE
<b>H4</b>	Gland Retainer	Stainless Steel (EN 1.4408)
<b>H5</b>	Anti-blowout Retaining Ring	Stainless Steel
<b>H6</b>	Packing Gland Stud	A4-70
<b>H7</b>	Flat Washer	Stainless Steel
<b>H8</b>	Disc Spring	17-7 PH
<b>H9</b>	Sleeve, Live Load	Stainless Steel
<b>H10</b>	Hex Nut	A4-70
<b>M1</b>	Mounting Bracket	Steel (Zinc Nickel Plated)
<b>M2</b>	Mounting Bracket Cap Screw	A4-70
<b>M3</b>	Mounting Bracket Lock Washer	Stainless Steel
<b>M4</b>	Mounting Bracket Pin	17-4 PH
<b>N1</b>	ID Tag	Stainless Steel
<b>N2</b>	Drive Screw	Stainless Steel
<b>N3</b>	Torque Tag	Stainless Steel
<b>N4</b>	Certification Tag	Stainless Steel
<b>P1</b>	Stem Key	17-4 PH

**NOTES**

- > Material specifications provided for reference only, and are subject to change without notice.
- > Additional materials available upon request.

## PRESSURE/TEMPERATURE RATINGS

### CARBON STEEL (1.0619)

#### MAXIMUM WORKING PRESSURE VS TEMPERATURE<sup>1</sup>

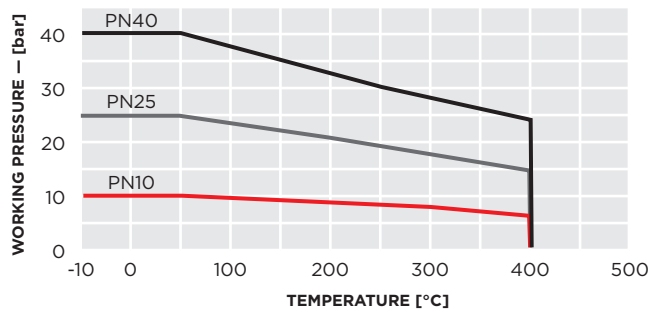

TEMP. °C	PN 10 bar	PN 25 bar	PN 40 bar
-10	10	25	40
0	10	25	40
20	10	25	40
50	10	25	40
100	9	23	37
150	9	22	36
200	8	21	34
250	8	19	31
300	7	17	28
350	7	16	26
400	6	15	24

### STAINLESS STEEL (1.4408)

#### MAXIMUM WORKING PRESSURE VS TEMPERATURE<sup>1</sup>

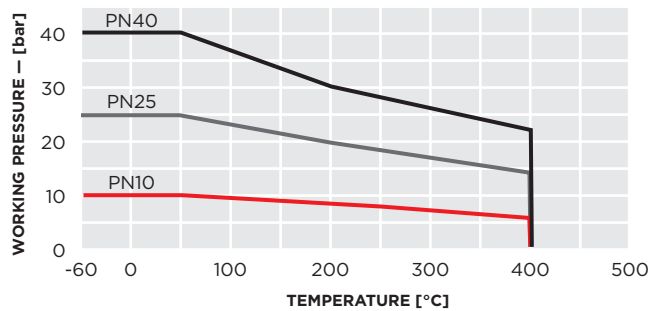

TEMP. °C	PN 10 bar	PN 25 bar	PN 40 bar
-60	10	25	40
0	10	25	40
20	10	25	40
50	10	25	40
100	10	24	38
150	9	21	34
200	8	19	30
250	7	18	28
300	6	16	26
350	6	15	25
400	6	15	24

#### NOTES

<sup>1</sup> Additional temperature limitations may apply based on valve trim and application conditions.

PN 10 | LUG (LA)

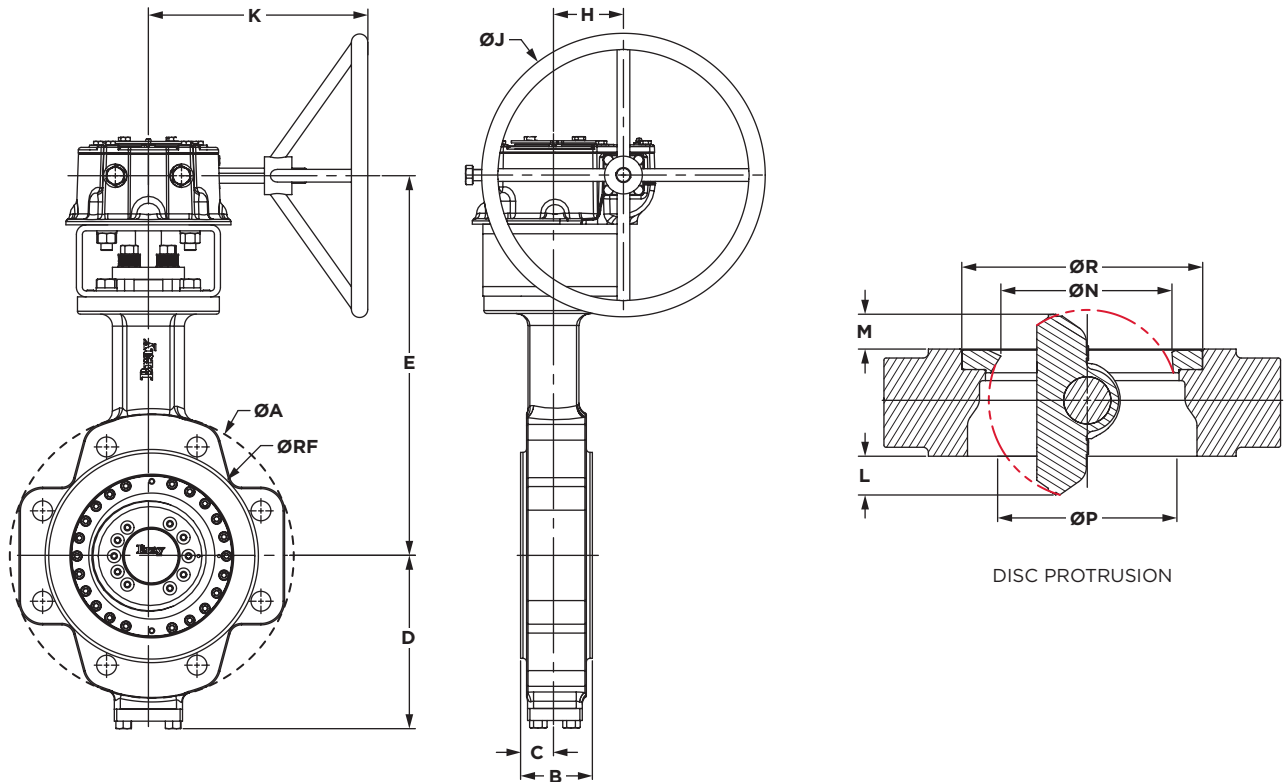

DIMENSIONS (mm)

DN <sup>1</sup>	ØA	B	C	D	E	G <sup>3</sup>	H	ØJ	K	Disc Protrusion					Flange Accommodation				Weight <sup>2</sup> (kg)
										L	M	ØN	ØP	ØR	ØRF	Bolt Circle	Hole Qty	Threads	
80	200	64	32	124	305	—	43	203	166	2	5	27	30	97	138	160	8	M16x2.0	22
100	219	64	32	141	335	—	55	203	174	12	15	66	63	122	158	190	8	M20x2.5	26
150	285	76	36	163	370	—	55	203	174	31	32	120	112	171	212	250	8	M24x3.0	43
200	340	89	43	203	404	—	55	305	209	46	48	165	157	221	268	295	8	M20x2.5	56
250	395	114	57	226	448	—	72	406	267	57	61	204	200	276	320	350	12	M20x2.5	92
300	445	114	57	262	525	—	93	508	300	82	86	261	255	327	370	400	12	M20x2.5	123
350	505	127	64	310	566	—	51	508	360	91	96	290	285	359	430	460	16	M20x2.5	195
400	565	140	70	339	597	—	51	508	360	107	115	334	334	410	482	515	16	M24x3.0	236
500	670	152	79	391	653	—	67	559	380	146	159	428	432	513	585	620	20	M24x3.0	329
600	780	178	94	475	772	—	153	635	476	180	198	523	531	616	685	725	20	M27x3.0	545

NOTES

- 1 For sizes not shown, contact Bray for more information.
- 2 Weights shown are for carbon steel bodies + gearbox.
- 3 G dimension is flange thickness (double flange body style only).

PN 10 | FLANGE (FA)

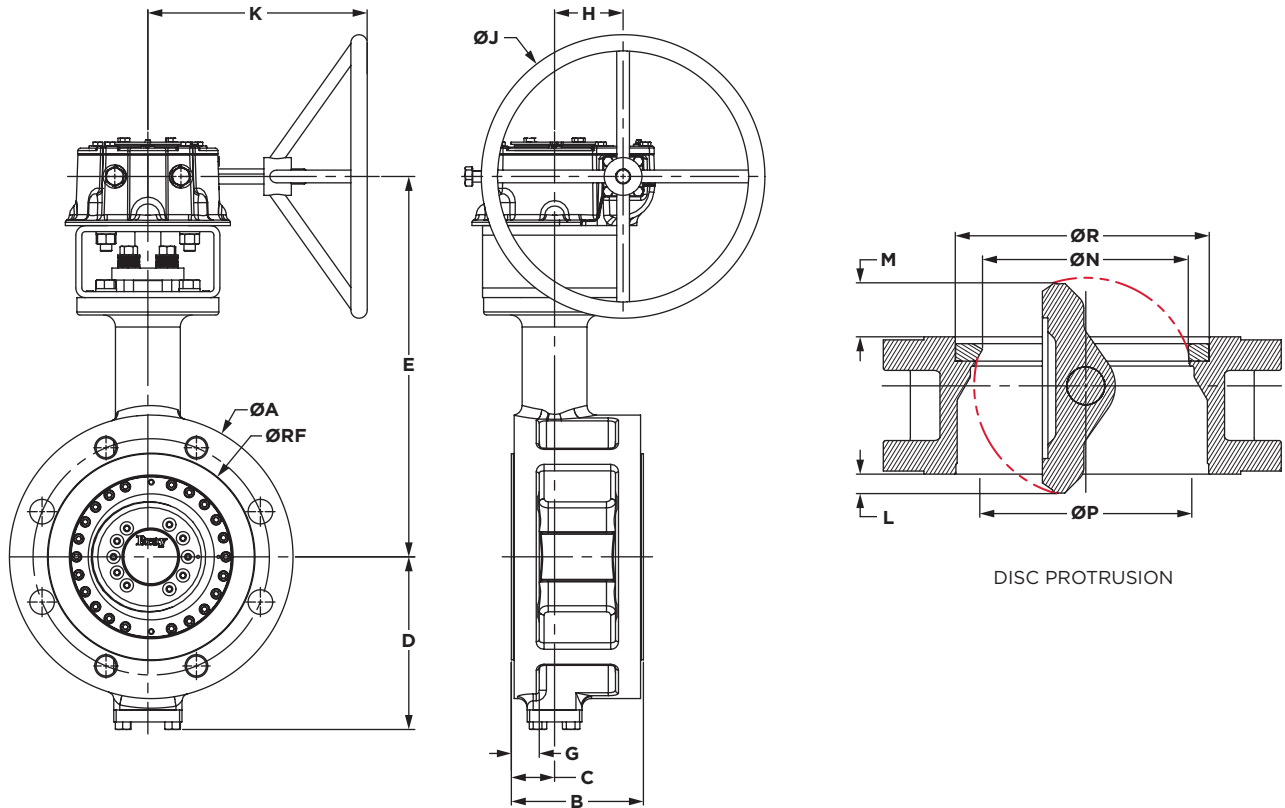

DIMENSIONS (mm)

DN <sup>1</sup>	ØA	B	C	D	E	G <sup>3</sup>	H	ØJ	K	Disc Protrusion				Flange Accommodation				Weight <sup>2</sup> (kg)	
										L	M	ØN	ØP	ØR	ØRF	Bolt Circle	Hole Qty		Threads
80	200	114	35	124	305	25	43	203	166	0	0	0	0	97	138	160	8	M16x2.0	27
100	220	127	39	141	335	22	55	203	174	5	0	45	0	122	158	180	8	M16x2.0	31
150	285	140	41	163	370	24	55	203	174	26	0	113	0	171	212	240	8	M20x2.5	53
200	340	152	43	203	404	25	55	305	209	46	0	165	0	221	268	295	8	M20x2.5	70
250	395	165	48	226	448	27	72	406	267	66	1	213	25	276	320	350	12	M20x2.5	103
300	445	178	56	262	525	27	93	508	300	83	21	262	142	327	370	400	12	M20x2.5	139
350	505	191	60	310	566	27	51	508	360	94	29	293	177	359	430	460	16	M20x2.5	208
400	565	216	64	339	597	27	51	508	360	114	32	339	201	410	582	515	16	M24x3.0	253
500	670	229	78	391	653	30	67	559	380	146	82	428	346	513	585	620	20	M24x3.0	340
600	780	267	93	475	772	36	153	635	476	181	109	524	437	616	685	725	20	M27x3.0	559

NOTES

- 1 For sizes not shown, contact Bray for more information.
- 2 Weights shown are for carbon steel bodies + gearbox.
- 3 G dimension is flange thickness (double flange body style only).

PN 25 | LUG (LC)

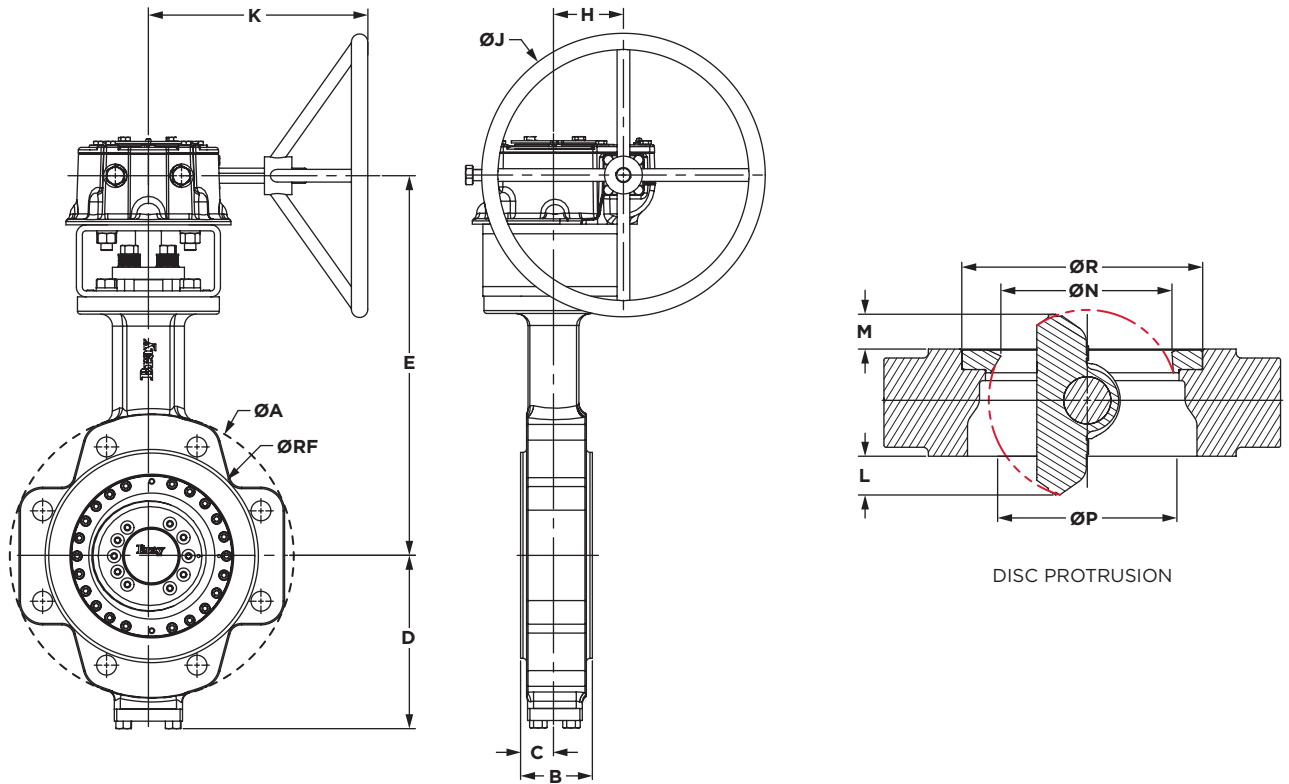

DIMENSIONS (mm)

DN <sup>1</sup>	ØA	B	C	D	E	G <sup>3</sup>	H	ØJ	K	Disc Protrusion					Flange Accommodation				Weight <sup>2</sup> (kg)
										L	M	ØN	ØP	ØR	ØRF	Bolt Circle	Hole Qty	Threads	
80	200	64	32	124	305	—	43	203	166	2	5	27	27	97	138	160	8	M16x2.0	22
100	235	64	32	141	335	—	55	203	174	12	15	66	63	122	162	190	8	M20x2.5	27
150	300	76	36	183	394	—	55	203	174	30	31	119	110	171	218	250	8	M24x3.0	53
200	360	89	44	229	462	—	55	305	209	44	48	160	155	221	278	310	12	M24x3.0	92
250	425	114	57	257	502	—	72	406	267	57	61	204	200	276	335	370	12	M27x3.0	125
300	485	114	56	303	545	—	93	508	300	82	88	264	257	329	395	430	16	M27x3.0	186
350	555	127	67	332	648	—	51	508	360	87	98	287	283	359	450	490	16	M30x3.5	269
400	620	140	73	370	679	—	51	508	360	105	118	337	333	410	505	550	16	M33x3.5	371
500	730	153	87	439	751	—	67	559	380	138	166	427	433	513	615	660	20	M33x3.5	550
600	845	178	102	529	855	—	153	635	476	175	208	515	548	616	720	770	20	M36x4.0	852

NOTES

- 1 For sizes not shown, contact Bray for more information.
- 2 Weights shown are for carbon steel bodies + gearbox.
- 3 G dimension is flange thickness (double flange body style only).

PN 25 | FLANGE (FC)

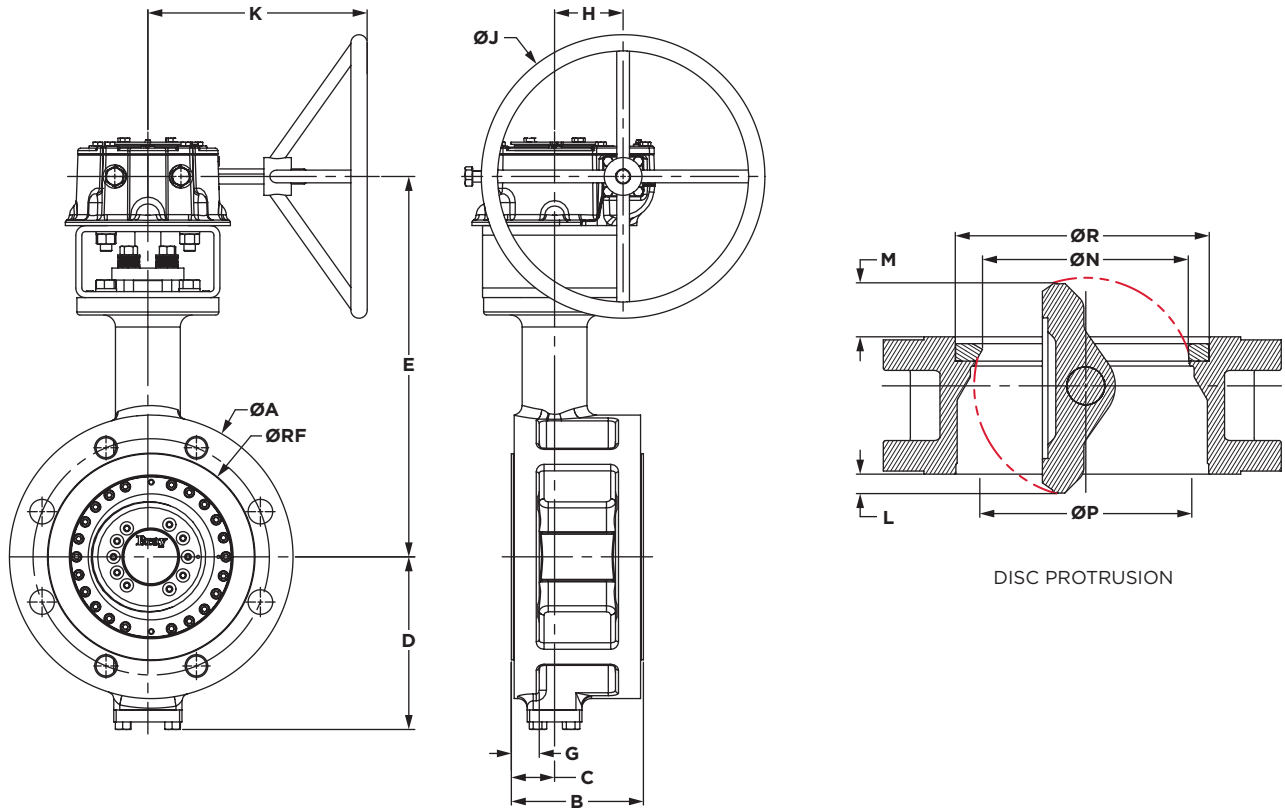

DIMENSIONS (mm)

DN <sup>1</sup>	$\varnothing A$	B	C	D	E	G <sup>3</sup>	H	$\varnothing J$	K	Disc Protrusion					Flange Accommodation			Weight <sup>2</sup> (kg)	
										L	M	$\varnothing N$	$\varnothing P$	$\varnothing R$	$\varnothing RF$	Bolt Circle	Hole Qty		Threads
80	200	114	35	124	305	25	43	203	166	0	0	0	0	97	138	160	8	M16x2.0	27
100	235	127	39	141	335	25	55	203	174	5	0	45	0	122	162	190	8	M20x2.5	34
150	300	140	46	183	394	29	55	203	174	21	0	104	0	171	218	250	8	M24x3.0	66
200	360	152	51	229	462	32	55	305	209	37	0	152	0	221	278	310	12	M24x3.0	109
250	425	165	51	257	502	34	72	406	267	62	4	211	57	276	335	370	12	M27x3.0	140
300	485	178	64	303	545	36	93	508	300	76	30	259	168	329	395	430	16	M27x3.0	207
350	555	191	74	332	648	40	51	508	360	80	42	280	204	359	450	490	16	M30x3.5	294
400	620	216	77	370	679	41	51	508	360	101	46	333	232	410	505	550	16	M33x3.5	409
500	730	229	102	439	751	50	67	559	380	124	105	414	376	513	615	660	20	M33x3.5	598
600	845	267	121	529	855	59	153	635	476	156	138	511	475	616	720	770	20	M36x4.0	922

NOTES

- 1 For sizes not shown, contact Bray for more information.
- 2 Weights shown are for carbon steel bodies + gearbox.
- 3 G dimension is flange thickness (double flange body style only).

PN 40 | LUG (LD)

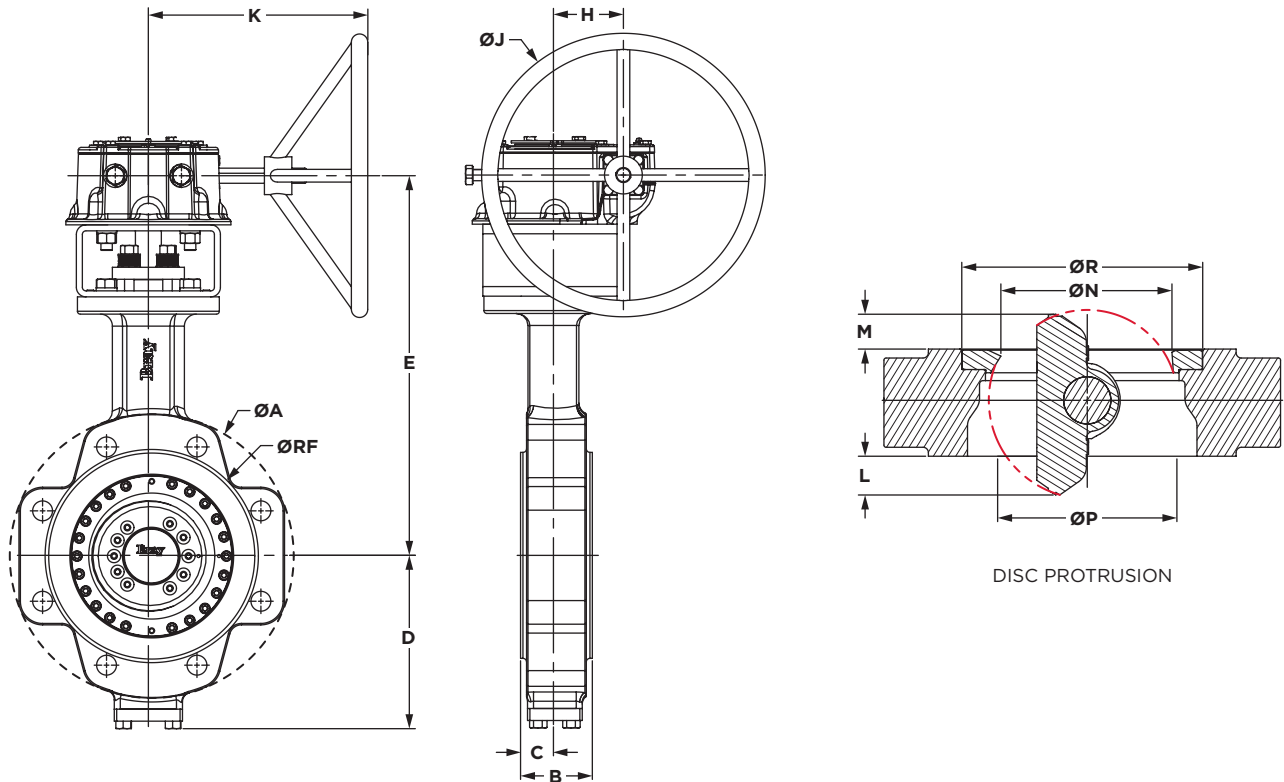

DIMENSIONS (mm)

DN <sup>1</sup>	ØA	B	C	D	E	G <sup>3</sup>	H	ØJ	K	Disc Protrusion					Flange Accommodation				Weight <sup>2</sup> (kg)
										L	M	ØN	ØP	ØR	ØRF	Bolt Circle	Hole Qty	Threads	
80	200	64	32	124	305	—	43	203	166	2	5	27	27	97	138	160	8	M16x2.0	22
100	235	64	32	141	335	—	55	203	174	12	15	66	63	122	162	190	8	M20x2.5	27
150	300	76	36	183	403	—	72	305	247	30	31	119	110	171	218	250	8	M24x3.0	53
200	375	89	44	229	482	—	51	305	315	44	48	160	155	221	285	320	12	M24x3.0	95
250	450	114	57	257	513	—	51	406	335	57	61	204	200	276	345	385	12	M30x3.5	137
300	515	114	58	303	552	—	67	559	380	82	88	264	257	329	410	450	16	M30x3.5	203
350	580	127	67	331	657	—	127	559	406	87	98	287	283	359	465	510	16	M33x3.5	286
400	660	140	73	370	689	—	153	635	476	105	118	337	333	410	535	585	16	M36x4.0	405
500	755	153	87	439	764	—	180	711	506	138	166	427	433	513	615	670	20	M39x4.0	576
600	890	178	102	529	862	—	202	711	526	175	208	515	548	616	735	795	20	M45x4.5	908

NOTES

- 1 For sizes not shown, contact Bray for more information.
- 2 Weights shown are for carbon steel bodies + gearbox.
- 3 G dimension is flange thickness (double flange body style only).

PN 40 | FLANGE (FD)

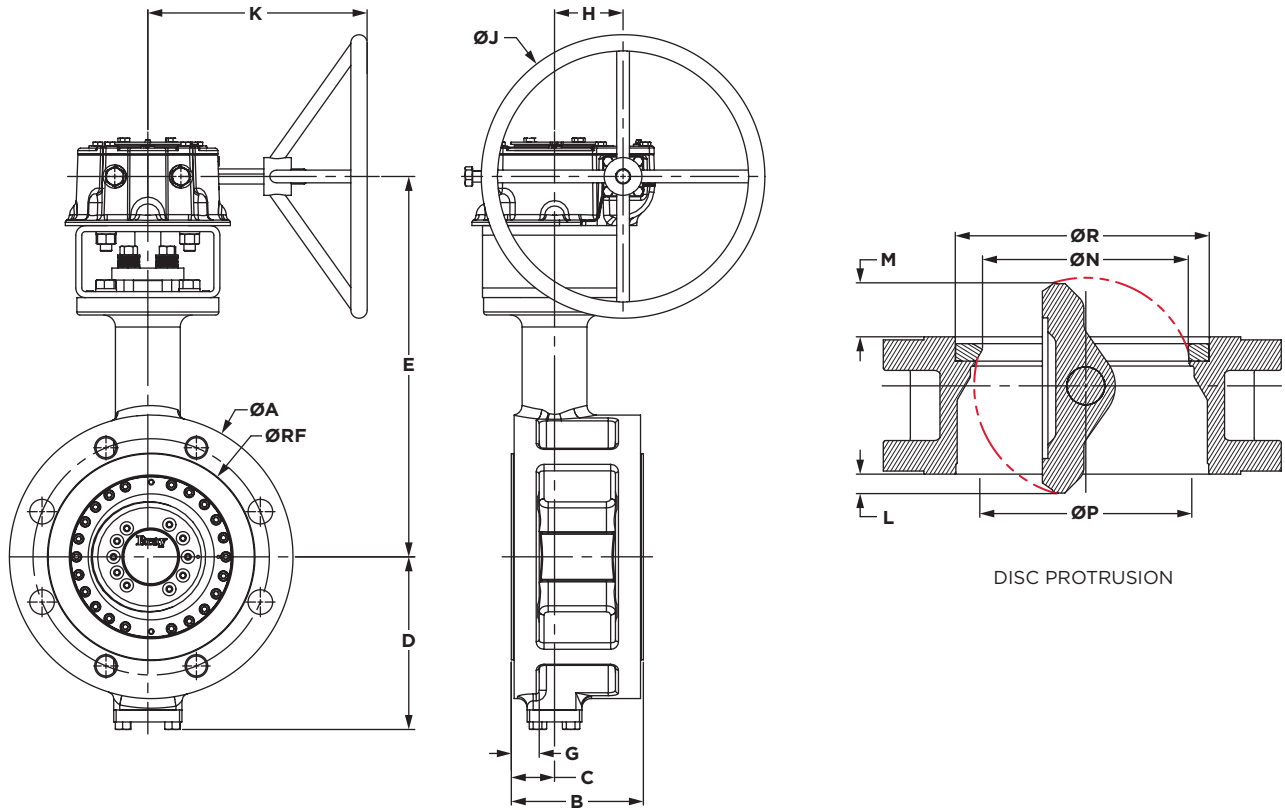

DIMENSIONS (mm)

DN <sup>1</sup>	$\varnothing A$	B	C	D	E	G <sup>3</sup>	H	$\varnothing J$	K	Disc Protrusion					Flange Accommodation				Weight <sup>2</sup> (kg)
										L	M	$\varnothing N$	$\varnothing P$	$\varnothing R$	$\varnothing RF$	Bolt Circle	Hole Qty	Threads	
80	200	114	35	124	305	25	43	203	166	0	0	0	0	97	138	160	8	M16x2.0	27
100	235	127	39	141	335	25	55	203	174	5	0	45	0	122	162	190	8	M20x2.5	34
150	300	140	46	183	403	29	72	305	247	21	0	104	0	171	218	250	8	M24x3.0	66
200	375	152	51	229	482	36	51	305	315	37	0	152	0	221	285	320	12	M27x3.0	116
250	450	165	51	257	513	40	51	406	335	62	4	211	57	276	345	385	12	M30x3.5	156
300	515	178	64	303	552	43	67	559	380	76	30	259	168	329	410	450	16	M30x3.5	229
350	580	191	74	331	657	47	127	559	406	80	42	280	204	359	465	510	16	M33x3.5	320
400	660	216	77	370	689	52	153	635	476	101	46	333	232	410	535	585	16	M36x4.0	459
500	755	229	102	439	764	58	180	711	506	124	105	414	376	513	615	670	20	M39x4.0	598
600	890	267	121	529	862	73	202	711	526	156	138	511	475	616	735	795	20	M45x4.5	1015

NOTES

- 1 For sizes not shown, contact Bray for more information.
- 2 Weights shown are for carbon steel bodies + gearbox.
- 3 G dimension is flange thickness (double flange body style only).

PN 10

VALVE SIZING COEFFICIENTS (Kv Values)									
DN	DISC POSITION (Degrees)								
	90°	80°	70°	60°	50°	40°	30°	20°	10°
80	59	59	52	42	32	23	15	8	2
100	122	123	108	87	67	48	31	16	4
150	442	445	391	316	241	173	112	58	16
200	932	937	822	666	508	364	236	123	34
250	1699	1708	1499	1215	927	665	431	224	63
300	2884	2899	2546	2062	1574	1128	731	381	106
350	3472	3491	3065	2483	1895	1359	880	459	128
400	5056	5083	4463	3615	2759	1978	1282	668	186
500	8718	8765	7696	6234	4757	3411	2210	1152	321
600	14225	14303	12558	10172	7763	5566	3606	1879	524

PN 25 | 40

VALVE SIZING COEFFICIENTS (Kv Values)									
DN	DISC POSITION (Degrees)								
	90°	80°	70°	60°	50°	40°	30°	20°	10°
80	59	59	52	42	32	23	15	8	2
100	122	123	108	87	67	48	31	16	4
150	342	344	302	245	187	134	87	45	13
200	716	720	632	512	391	280	181	95	26
250	1514	1522	1337	1083	826	592	384	200	56
300	2370	2383	2093	1695	1294	927	601	313	87
350	2581	2595	2278	1845	1408	1010	654	341	95
400	4453	4477	3931	3184	2430	1742	1129	588	164
500	6926	6963	6114	4952	3779	2710	1756	915	255
600	10733	10791	9475	7675	5857	4199	2721	1418	395

NOTES

- > Kv varies with the valve size, angle of opening and the manufacturer's valve style.
- > Kv value is the volume of water in cubic meters/hour (m<sup>3</sup>/hr) that will flow through a given restriction or valve opening with a pressure drop of one (1) bar at room temperature.
- > For sizes not shown, contact Bray for more information.

## FLANGE TO VALVE BOLTING DATA

### LUG VALVE WITH STUDS

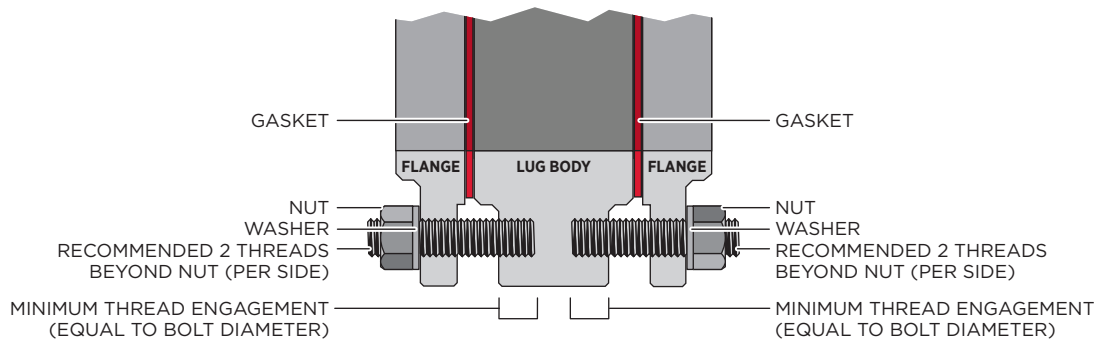

### DOUBLE FLANGE VALVE WITH THROUGH-STUDS

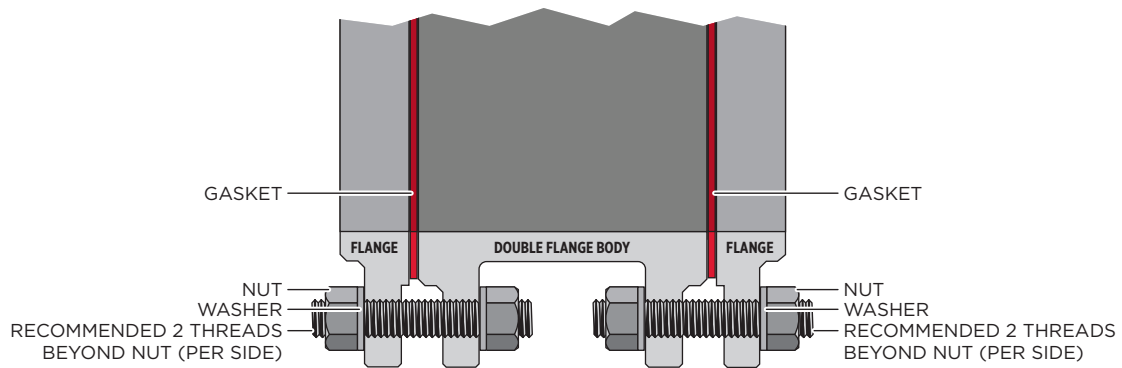

### IMPORTANT INFORMATION

- > Refer to appropriate Bray dimensional drawings for specific valve drilling information.
- > Lug threads may be tapped from both sides, and therefore tap may not be continuous.
- > Minimum bolt engagement must be equal to the diameter of the bolt.
- > When bolting the valve into the line, use standard bolting torque as recommended by applicable piping standards. Additional force from the flange bolts is not required.

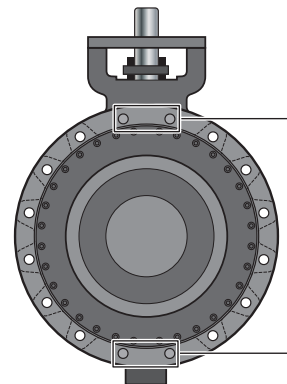

**CAUTION**  
Tapped holes at the bearing hub areas **do not** permit through-holes.

## FLANGE TO VALVE BOLTING DATA

### PN 10 | LUG

Valve Size	Fastener Size	Stud		Blind Stud		Washer	Hex Nut
DN	Ø-Thread	Length (mm)	Qty	Length (mm)	Qty	Qty	Qty
80	M16 x 2.0	90	16	—	—	16	16
100	M16 x 2.0	90	16	—	—	16	16
150	M20 x 2.5	110	16	—	—	16	16
200	M20 x 2.5	110	16	—	—	16	16
250	M20 x 2.5	110	24	—	—	24	24
300	M20 x 2.5	110	24	—	—	24	24
350	M20 x 2.5	110	24	—	—	24	24
400	M24 x 3.0	130	32	110	8	40	40
500	M24 x 3.0	130	32	120	8	40	40
600	M27 x 3.0	140	32	130	8	40	40

### PN 10 | DOUBLE FLANGE

Valve Size	Fastener Size	Stud		Blind Stud		Washer	Hex Nut
DN	Ø-Thread	Length (mm)	Qty	Length (mm)	Qty	Qty	Qty
80	M16 x 2.0	110	8	80	8	24	24
100	M16 x 2.0	110	8	80	8	24	24
150	M20 x 2.5	120	8	100	8	24	24
200	M20 x 2.5	130	8	100	8	24	24
250	M20 x 2.5	130	8	100	16	32	32
300	M20 x 2.5	130	8	100	16	32	32
350	M20 x 2.5	130	24	100	8	56	56
400	M24 x 3.0	140	24	120	8	56	56
500	M24 x 3.0	150	24	120	16	64	64
600	M27 x 3.0	160	24	140	16	64	64

#### NOTES

1. All studs are in accordance with DIN 976-1. Rounded to standard lengths.
2. All nuts are in accordance with ISO 4033 Table 1.
3. All washers are in accordance with DIN 887, Normal Series Washers.
4. Length calculations include 2 washers per stud and hex nut configuration and 1 washer per stud and hex nut (blind) configuration.
5. Standard spiral wound gaskets accordance with BS EN 1514-2, one per side, have been included in the bolting calculations.
6. Stud and hex nut (blind) specifies special stud lengths for the threaded flange bolt holes closest to the valve stem.
7. Contact Bray for any sizes or configurations not shown.

**PN 25 | LUG**

Valve Size	Fastener Size	Stud		Blind Stud		Washer	Hex Nut
DN	Ø-Thread	Length (mm)	Qty	Length (mm)	Qty	Qty	Qty
80	M16 x 2.0	100	16	—	—	16	16
100	M20 x 2.5	110	16	—	—	16	16
150	M24 x 3.0	130	16	—	—	16	16
200	M24 x 3.0	130	16	110	8	24	24
250	M27 x 3.0	140	24	—	—	24	24
300	M27 x 3.0	140	24	120	8	32	32
350	M30 x 3.5	150	24	130	8	32	32
400	M33 x 3.5	170	24	140	8	32	32
500	M33 x 3.5	170	32	150	8	40	40
600	M36 x 4.0	190	32	170	8	40	40

**PN 25 | DOUBLE FLANGE**

Valve Size	Fastener Size	Stud		Blind Stud		Washer	Hex Nut
DN	Ø-Thread	Length (mm)	Qty	Length (mm)	Qty	Qty	Qty
80	M16 x 2.0	110	8	90	8	24	24
100	M20 x 2.5	130	8	100	8	24	24
150	M24 x 3.0	150	8	120	8	24	24
200	M24 x 3.0	150	8	120	16	32	32
250	M27 x 3.0	160	8	130	16	32	32
300	M27 x 3.0	160	16	130	16	48	48
350	M30 x 3.5	190	16	140	16	48	48
400	M33 x 3.5	190	16	150	16	48	48
500	M33 x 3.5	220	24	160	16	64	64
600	M36 x 4.0	240	24	200	16	64	64

**NOTES**

1. All studs are in accordance with DIN 976-1. Rounded to standard lengths.
2. All nuts are in accordance with ISO 4033 Table 1.
3. All washers are in accordance with DIN 887, Normal Series Washers.
4. Length calculations include 2 washers per stud and hex nut configuration and 1 washer per stud and hex nut (blind) configuration.
5. Standard spiral wound gaskets accordance with BS EN 1514-2, one per side, have been included in the bolting calculations.
6. Stud and hex nut (blind) specifies special stud lengths for the threaded flange bolt holes closest to the valve stem.
7. Contact Bray for any sizes or configurations not shown.

## FLANGE TO VALVE BOLTING DATA

### PN 40 | LUG

Valve Size	Fastener Size	Stud		Blind Stud		Washer	Hex Nut
DN	Ø-Thread	Length (mm)	Qty	Length (mm)	Qty	Qty	Qty
80	M16 x 2.0	100	16	—	—	16	16
100	M20 x 2.5	110	16	—	—	16	16
150	M24 x 3.0	130	16	—	—	16	16
200	M27 x 3.0	140	16	120	8	24	24
250	M30 x 3.5	150	24	—	—	24	24
300	M30 x 3.5	160	24	130	8	32	32
350	M33 x 3.5	170	24	150	8	32	32
400	M36 x 4.0	190	24	160	8	32	32
500	M39 x 4.0	200	32	170	8	40	40
600	M45 x 4.5	240	32	200	8	40	40

### PN 40 | DOUBLE FLANGE

Valve Size	Fastener Size	Stud		Blind Stud		Washer	Hex Nut
DN	Ø-Thread	Length (mm)	Qty	Length (mm)	Qty	Qty	Qty
80	M16 x 2.0	110	8	90	8	24	24
100	M20 x 2.5	130	8	100	8	24	24
150	M24 x 3.0	150	8	120	8	24	24
200	M27 x 3.0	160	8	130	16	32	32
250	M30 x 3.5	190	8	140	16	32	32
300	M30 x 3.5	190	16	150	16	48	48
350	M33 x 3.5	220	16	160	16	48	48
400	M36 x 4.0	220	16	170	16	48	48
500	M39 x 4.0	260	24	190	16	64	64
600	M45 x 4.5	300	24	240	16	64	64

#### NOTES

1. All studs are in accordance with DIN 976-1. Rounded to standard lengths.
2. All nuts are in accordance with ISO 4033 Table 1.
3. All washers are in accordance with DIN 887, Normal Series Washers.
4. Length calculations include 2 washers per stud and hex nut configuration and 1 washer per stud and hex nut (blind) configuration.
5. Standard spiral wound gaskets accordance with BS EN 1514-2, one per side, have been included in the bolting calculations.
6. Stud and hex nut (blind) specifies special stud lengths for the threaded flange bolt holes closest to the valve stem.
7. Contact Bray for any sizes or configurations not shown.

---

SINCE 1986, BRAY HAS PROVIDED FLOW CONTROL SOLUTIONS FOR A VARIETY OF INDUSTRIES AROUND THE WORLD.

VISIT **BRAY.COM** TO LEARN MORE ABOUT BRAY PRODUCTS AND LOCATIONS NEAR YOU.

## **GLOBAL HEADQUARTERS**

### **Bray International, Inc.**

13333 Westland East Blvd.

Houston, Texas 77041

Tel: +1.281.894.5454

All statements, technical information, and recommendations in this bulletin are for general use only. Consult Bray representatives or factory for the specific requirements and material selection for your intended application. The right to change or modify product design or product without prior notice is reserved. Patents issued and applied for worldwide. Bray® is a registered trademark of Bray International, Inc.

© 2023 BRAY INTERNATIONAL. ALL RIGHTS RESERVED. BRAY.COM

EN\_TSM\_TRILOK\_Cx\_20251201\_02

---



**THE HIGH PERFORMANCE COMPANY**

**BRAY.COM**