

---

**SERIES 765**

# **BIDIRECTIONAL SLURRY VALVES**

Operation, and Maintenance Manual

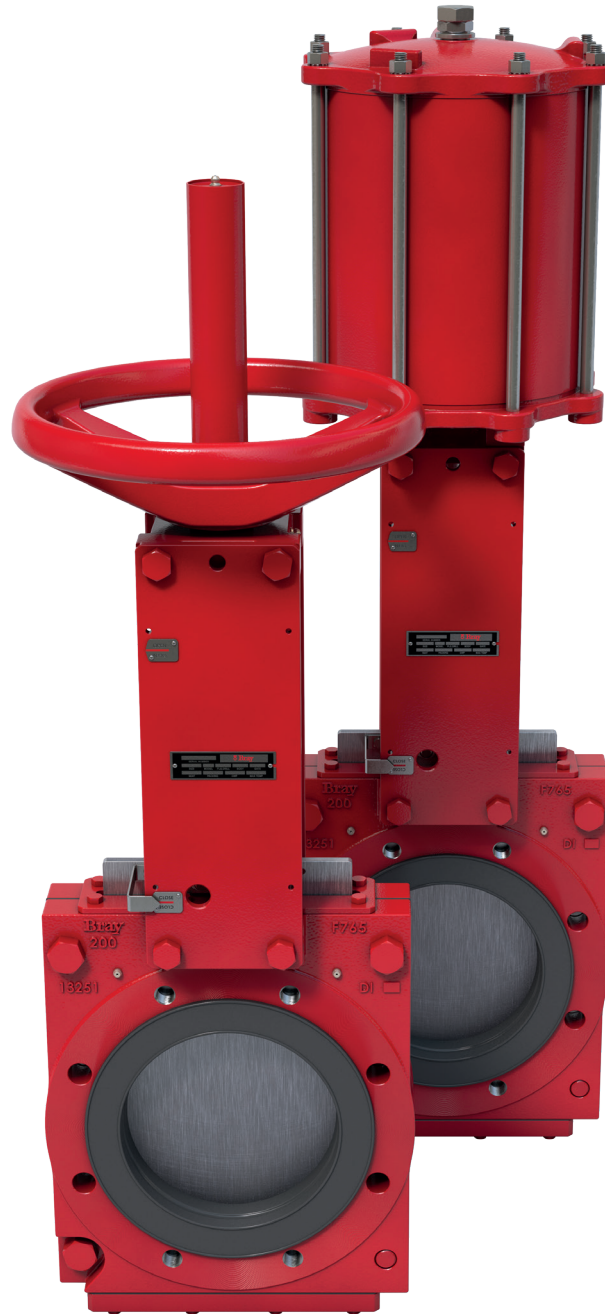

---

 **Bray**<sup>®</sup>

**BRAY.COM**

**THE HIGH PERFORMANCE COMPANY**

---

## Table of Contents



Definition of Terms . . . . .	1
Safety Instructions. . . . .	1
Introduction. . . . .	2
Unpacking . . . . .	2
Storage . . . . .	3
Installation . . . . .	4
Commissioning . . . . .	4
Cylinder-Operated Valves . . . . .	4
Manual Valves . . . . .	4
Valve Maintenance . . . . .	4
Lubrication . . . . .	4
Secondary Seal Replacement . . . . .	5
Manual Valves . . . . .	5
Cylinder-Operated Valves . . . . .	5
Stroke Length Tables . . . . .	6
Seat Replacement - No Retainer . . . . .	6
Actuator Maintenance . . . . .	7
Spare Parts . . . . .	7
Troubleshooting. . . . .	7

---

## Definition of Terms - Safety Instructions

**READ AND FOLLOW THESE INSTRUCTIONS**  
**SAVE THESE INSTRUCTIONS**

### DEFINITION OF TERMS

 <b>WARNING</b>	Indicates a potentially hazardous situation which, if not avoided, could result in death or serious injury.
 <b>CAUTION</b>	Indicates a potentially hazardous situation which, if not avoided, may result in minor or moderate injury.
<b>NOTICE</b>	Used without the safety alert symbol indicates a potential situation which, if not avoided, may result in an undesirable result or state, including property damage.

### HAZARD-FREE USE

This device left the factory in proper condition to be safely installed and operated in a hazard-free manner. The notes and warnings in this document must be observed by the user if this safe condition is to be maintained and hazard-free operation of the device assured.

Take all necessary precautions to prevent damage to the valve due to rough handling, impact, or improper storage. Do not use abrasive compounds to clean the valve, or scrape metal surfaces with any objects.

The control systems in which the valve is installed must have proper safeguards to prevent injury to personnel, or damage to equipment, should failure of system components occur.

### QUALIFIED PERSONNEL

- A qualified person in terms of this document is one who is familiar with the installation, commissioning, and operation of the device and who has appropriate qualifications, such as:
- Is trained in the operation and maintenance of electrical equipment and systems in accordance with established safety practices
- Is trained or authorized to energize, de-energize, ground, tag, and lock electrical circuits and equipment in accordance with established safety practices
- Is trained in the proper use and care of personal protective equipment (PPE) in accordance with established safety practices
- Is trained in first aid
- In cases where the device is installed in a potentially explosive (hazardous) location – is trained in the commissioning, operation, and maintenance of equipment in hazardous locations

 **WARNING**

The valve must only be installed, commissioned, operated, and repaired by qualified personnel.

The device generates a large mechanical force during normal operation.

All installation, commissioning, operation, and maintenance must be performed under strict observation of all applicable codes, standards, and safety regulations.

Observe all applicable safety regulations for valves installed in potentially explosive (hazardous) locations.

## INTRODUCTION

The Bray Slurry Series 765 provides repeatable bidirectional shutoff in a rugged, cast body.

Additional information about Slurry Series valves – including application data, engineering specifications, and actuator selection is available from your Bray distributor or sales representative.

## UNPACKING

Ensure the box is not damaged externally. Remove the valve from the packaging and check for any damage to the valve and its components during transit.

All valves, actuators, or control products are provided with an identification tag that is unique to each device. The following table is a representation of information that may be included.

**Valve Identification**

Data	Label	Description
Serial Number	SERIAL NUMBER	Unique serial number of valve.
Valve Size	SIZE	Valve size e.g. 6 in/150 mm.
Model	MODEL	Series number of the Valve
Flange Drill	FLG. DRILL	Flange Drill e.g. ASME B16.5 CL150.
Temperature Limits	MAX TEMP	Maximum temperature in °F/°C
Maximum Permissible Pressure	CWP	Maximum permissible pressure in psi/bar(g)
Body Material	BODY	Material grade of body e.g. CF8 (304) etc.
Gate Material	GATE	Material grade of gate e.g. 304 Stainless Steel.
Packing Material	PACKING	Material of packing e.g. PTFE w/ EPDM Quad Seal.
Seat Material	SEAT	Material of seat e.g. Buna-N.

## STORAGE

### NOTICE

The packaging is designed to protect the valve only during shipping. If you are not installing the valve immediately after delivery, then you must store it according to these requirements.

Failure to follow these procedures could affect product warranty.

### SHORT-TERM STORAGE

Short-term storage is defined as storage of valves to allow for project construction and will be installed within a relatively short amount of time (typically one to three months). During short-term storage, the following is required:

The preferred storage location is a clean, dry, protected warehouse. Do not expose the valve to temperature extremes. End protectors shall remain on the valve ends to prevent the entrance of dirt, debris, or insects/wildlife.

Remain in the original shipping container with the original packaging materials. This packaging method will not protect valves that will be stored outside, uncovered, and unprotected.

Storage of valves in an open, uncovered area is permissible, but requires provisions for inclement weather. The product must be elevated from the ground on a pallet, a shelf, or other suitable surface, and must be covered with a secure, waterproof tarp.

Do not stack the valves on top of each other.

Manually actuated valves may be stored in the vertical or horizontal position. For air or hydraulic actuated valves, the preferred orientation is with the valve and cylinder in the vertical position. Access ports should be secured to prevent unauthorized entry and prevent contamination.

### LONG-TERM STORAGE

Long-term storage is defined as storage of valves longer than three months. During long-term storage, the following is required:

The storage location shall be a clean, dry, protected warehouse. Do not expose the valve to temperature extremes.

End protectors shall remain on the valve ends to prevent the entrance of dirt, debris, or insects/wildlife.

Product shall remain in the original shipping container with the original packaging materials.

Do not stack the valves on top of each other.

Manually actuated valves may be stored in the vertical or horizontal position. For air or hydraulic actuated valves, the preferred orientation is with the valve and cylinder in the vertical position. Access ports should be secured to prevent unauthorized entry and prevent contamination.

Valves and equipment containing elastomers, including O-rings, must be stored in a climate-controlled warehouse according to SAE-ARP5316D requiring:

- > The ambient relative humidity to be less than 75%.
- > No exposure from direct ultraviolet or sunlight.
- > Protection from ozone generating equipment or combustible gases and vapors.
- > Storage at temperatures below 100°F (38°C), away from direct sources of heat.
- > No exposure to ionizing radiation.

Storage inspection — visual inspection shall be performed on a semi-annual basis and results recorded. Inspection, as a minimum, shall include reviewing the following:

- > Packaging.
- > Flange covers.
- > Dryness.
- > Cleanliness.

Actuators to be stored with all cable/pneumatic entries plugged to prevent entry of foreign material.

Leave protective caps and covers on the product.

## INSTALLATION

- Valves can be mounted with flow in both directions.
- Install the valve between flanges using fasteners.

 **CAUTION**

Support should be used for valves size 8" and over when installed in vertical pipe. Failure to do so can result in improper valve operation and/or valve failure.

## COMMISSIONING GUIDELINES

### Cylinder Operated Valves

1. Connect instrument quality air, preferably through an air filter/regulator of adequate size. The recommended air pressure is 80-100 psi (5-8 bar). Refer to the appropriate bulletin/drawing for port and cylinder size details.
2. Ensure the supply air is free from moisture, dirt, and other foreign particles. Drain the filter regulator before operating the actuator so that pipe rust and dirt if any in the air line will be removed before actuation.
3. If valves are supplied with electrical accessories like limit switch and solenoid valve, ensure wiring is done as per local electrical safety codes and regulations. Ensure correct electrical supply is given to electrical accessories for proper functioning and safety of the equipment.
4. Open the valve by energizing the solenoid valve/giving air supply to cylinder and operate the valve 2-3 times.

### Manual Valves

Open/Close the valve manually and observe valve operation.

 **CAUTION**

Wrong electrical supply to accessories will damage the equipment. Do not over tighten the gland nuts as this may cause excessive friction and premature damage to packing.

## MAINTENANCE

**NOTICE**

Any modification or use of unauthorized parts voids any and all warranty considerations.

### Lubrication

The manual valve stem should be lubricated at regular intervals for smooth operation of the valve. A lubrication nipple is provided on the collar. Cylinder operated valves do not require routine lubrication.

**NOTICE**

If the cylinder actuator is disassembled for repair, the cylinder wall and seals need to be lubricated with a lithium-based grease prior to reassembly.

## Secondary Seal Replacement

1. Relieve the line pressure.
2. Fully close the valve.
3. Ensure the line is empty, and flush if necessary.

## Manual Valves

1. Disconnect the stem from the gate by removing the clevis bolt and nuts
2. Rotate the Hand wheel counter clockwise by holding the stem from rotation, so that stem retracts fully from the gate.
3. If valves are supplied with bellows, ensure stem is not rotating, as rotation will damage the bellows.
4. Remove the secondary seal retainer bolts (6).
5. Remove the seal retainer (5), wiper (4) (if applicable) and old secondary seal (3) from the packing chamber, using a long thin tool to pry it out.
6. Insert the new secondary seal (3) into the packing chamber.
7. Re-attach the wiper (4), if applicable, and secondary seal retainer (5) onto the valve body.
8. Tighten the secondary seal retainer bolts (6).
9. Lower the stem by rotating the hand wheel clockwise while holding the stem and fasten the stem to the gate with nuts & bolts.
10. Adjust the gate positions from top of the body according to the following tables.

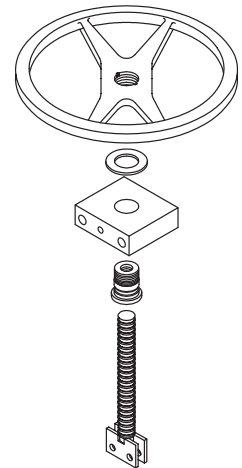

**Manual Valve Stem**

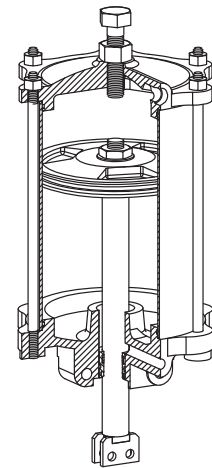

**Cylinder Actuator**

## Cylinder-Operated Valves

1. Switch off the electrical supply to the solenoid and limit switches.
2. Remove the cylinder tubing and vent the air inside the cylinder.
3. Disconnect the piston rod from the gate by removing the clevis bolts & nuts.
4. Apply air slightly to the bottom port of the actuator so that the piston rod is retracted from the gate.
5. Remove the actuator assembly from the valve by removing the fasteners connecting the yokes to the valve body.
6. Remove the secondary seal retainer bolts (6).
7. Remove the seal retainer (5), wiper (4), if applicable and old secondary seal (3) from the packing chamber, using a long thin tool to pry it out.
8. Insert the new secondary seal (3) into the packing chamber.
9. Re-attach the wiper (4), if applicable, and secondary seal retainer (5) onto the valve body.
10. Tighten the secondary seal retainer bolts (6).
11. Mount the actuator and superstructure on the valve.
12. Connect the gate (2) and stem by clevis bolts and nuts
13. Apply air slightly for cylinder operated valves to lower the piston rod and fasten the gate.
14. Adjust and ensure the gate positions from top of the body according to the following tables as appropriate.

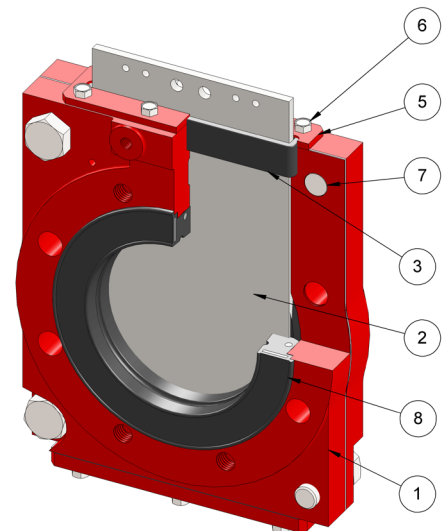

**Without Seal Retainer**

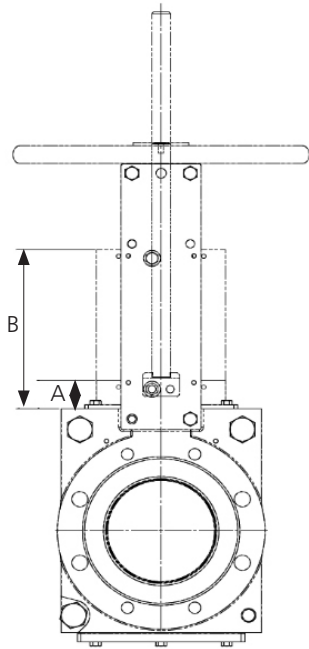

Series 765			
Valve Size		A (mm)	B (mm)
DN	NPS		
50	2	41	117
80	3	41	149
100	4	41	180
125	5	41	210
150	6	42	232
200	8	44	289
250	10	47	350
300	12	53	414

Stroke Length

### CAUTION

Relieve line pressure before attempting to remove the valve from the line to avoid personnel injury and/or equipment damage. If the valve has a pneumatic actuator, solenoid valve, limit switches, or other accessories, disconnect the electrical and pneumatic supply.

## Seat Replacement

1. Relieve the line pressure and close the valve. Flush the line if necessary.
2. Remove the valve from the line by loosening the flange mounting bolts, studs, and nuts.
3. Clamp the valve in the vertical position up to 12" & in the horizontal position for the sizes above 12" to a fixture. Do not block the valve port when clamping the valve. An overhead hoist may be needed for larger size valves.
4. Retract the gate to full open condition.
5. Remove the seats (8) from the valve.
6. Verify that the circular bore is clear of all debris, scale, and elastomer residue.
7. Lay the valve down in a horizontal position on a flat surface.
8. Lubricate the O.D. and sealing lip of the first seat. Use recommended lubricants
9. Install the seat (8), being careful to center the flange end in the bore of the housing.
10. Lubricate the O.D. and sealing lip of the second seat. Use recommended lubricants
11. Install the second seat. Using a straight edge, check the seat position in four places, 90 degrees apart in relation to the replaced seat bore. Adjust as required to make the seat concentric with the other seat.
12. The valve is now ready for installation. The gate must remain in the open position until the valve is installed and ready for operation.



## ACTUATOR MAINTENANCE

### Pneumatic Cylinder

The Bray pneumatic cylinder actuator is a low maintenance design and does not require routine maintenance. It has an FRP tube which is lubricated for life with a special coating on the inside wall. Filtered dry, instrument quality air (non-lubricated) should be used for its operation at the specified air supply pressure.

### Recommended Spare Parts

Following are parts recommended as spares, which may be stocked. Following are general recommended spares for valves. Provide the valve serial number and work order number from the nameplate for proper parts.

- Secondary Seal, Wiper
- Spare Seat
- Cylinder repair kit

### Troubleshooting

Trouble	Possible cause	Solution
In fully closed position, valve leaks	Seat is worn out or torn	Replace seat
	Gate is scratched	Replace gate
High torque during valve seating and unseating	Misalignment between gate and stem	<ol style="list-style-type: none"> <li>1. Remove the clevis fasteners</li> <li>2. Loosen the superstructure fasteners</li> <li>3. Adjust the alignment of the stem and gate</li> <li>4. Connect the clevis fasteners</li> <li>5. Retighten superstructure fasteners</li> </ol>
Valve jerks during open and close	Superstructure fasteners loosen	Tighten the super structure fasteners
	Insufficient air supply	Pneumatic operated valves: Increase supply pressure
	Solenoid valve dust accumulation	Remove and clean solenoid valve
	Piston rod seal damaged	Replace seal

All statements, technical information, and recommendations in this bulletin are for general use only. Consult Bray representatives or factory for the specific requirements and material selection for your intended application. The right to change or modify product design or product without prior notice is reserved. Patents issued and applied for worldwide.

Bray® is a registered trademark of  
Bray International, Inc.  
© 2015 Bray International, Inc. All rights reserved.

OM\_Slurry Series765\_12\_2021

---



**Bray International, Inc.**  
13333 Westland East Blvd.  
Houston, Texas 77041  
Tel: 281.894.5454 • [www.bray.com](http://www.bray.com)