

---

KMSP/KMHP/KMHT/KMPT

# BALL VALVES

Installation, Operation, and Maintenance Manual

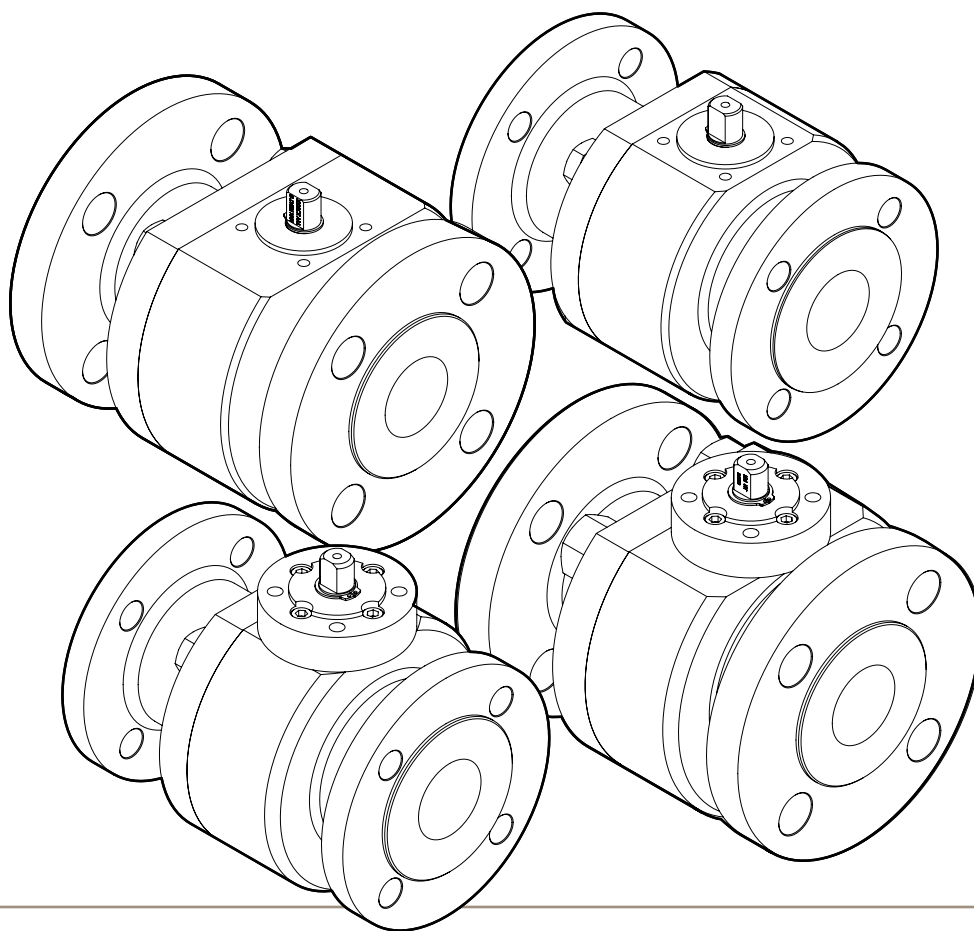

**CONTENTS**

1.0	Definition of Terms . . . . .	4
2.0	Introduction . . . . .	5
3.0	Valve Identification . . . . .	6
4.0	Intended Use. . . . .	7
4.1	Hazard-Free Use. . . . .	7
4.2	Hazardous Environments (ATEX). . . . .	8
5.0	Qualified Personnel . . . . .	9
6.0	Handling Requirements. . . . .	10
6.1	Packed Valves. . . . .	10
6.2	Unpacked Valves . . . . .	10
7.0	Storage. . . . .	11
7.1	Short-term Storage . . . . .	11
7.2	Long-term Storage . . . . .	11
8.0	Lifting. . . . .	13
8.1	Handlever. . . . .	13
8.2	Valve with Gear Operator. . . . .	13
8.3	Valve with Pneumatic Actuator. . . . .	13
9.0	Bill of Material . . . . .	14
9.1	KMSP (O-Ring Sealing System) . . . . .	14
9.2	KMHP (O-Ring Sealing System) . . . . .	15
9.3	KMHT (O-Ring Sealing System) . . . . .	16
9.4	KMPT (O-Ring Sealing System) . . . . .	17
10.0	Installation Considerations / Safety Instructions . . . . .	18
10.1	Piping and Flange Compatibilities (Metal Flanges) . . . . .	18
10.2	Valves with Spring Return Actuators. . . . .	19
10.3	Valve Location . . . . .	19
10.4	Valve Orientation . . . . .	19
11.0	Installation & Commissioning . . . . .	20
11.1	General. . . . .	20
11.2	Valve-Actuator-Assembly. . . . .	23
11.3	Pressure Testing & Commissioning. . . . .	23
11.4	Valve Removal . . . . .	24
12.0	Operation and Maintenance . . . . .	25



---

12.1	Normal Operation	25
12.2	Maintenance	26
13.0	Disassembly/Assembly Instructions	27
13.1	Disassembly: stem and seal removal	27
13.2	Visual Inspection	27
13.3	Assembly	28
13.4	Testing	29
14.0	Troubleshooting	30
15.0	Return Merchandise Authorization	31
APPENDIX A:	Conformity of EU Directives	32

## 1.0 DEFINITION OF TERMS

- 1.1 All information within this manual is relevant to the safe operation and proper care of your Kugelhahn Müller valve. Please understand the following examples of information used throughout this manual.

### SAFETY STATEMENTS

The terms DANGER, WARNING, CAUTION, and NOTICE are used in this document to prevent unwanted consequences. Standard symbols and classifications are:



#### DANGER

Indicates an immediate hazardous situation which, if not avoided, **will** result in death or serious injury and/or property damage.



#### WARNING

Indicates a potentially hazardous situation which, if not avoided, **could** result in death or serious injury and/or property damage.



#### CAUTION

Indicates a potentially hazardous situation which, if not avoided, **may** result in minor or moderate injury and/or property damage.



#### NOTICE

Indicates and provides additional technical information which may not be obvious, even to qualified personnel. The term is not used for personal injury hazards or warnings, but can be used to indicate possible equipment or property damage.

- 1.2 Compliance with other notes — regarding transport, assembly, operation & maintenance, and about technical documentation (e.g., in the operating instructions, product documentation, or on the product itself) — is essential, to avoid faults which can directly or indirectly cause severe personal injury or property damage.

## 2.0 INTRODUCTION



### NOTICE

Failure to follow these procedures could affect product warranty.

**Read and follow these instructions carefully and keep this manual in a safe place for future reference.**

### 2.1 **Read and follow these instructions carefully and keep this manual in a safe place for future reference.**

**2.2** This manual is intended to assist the user in the installation, operation and maintenance of ball valves. It presupposes that all pipeline-specific regulations – insofar as these apply to ball valves – are also observed.

For a mounted actuator, the associated manufacturer's documentation must also be observed.

**2.3** This device left the factory in proper condition to be safely installed and operated in a hazard-free manner. The notes and warnings in this document must be observed by the user if this safe condition is to be maintained and hazard-free operation of the device assured.

**2.4** Take all necessary precautions to prevent damage to the valve due to rough handling, impact, or improper storage. Do not use abrasive compounds to clean the valve, or scrape metal surfaces with any objects.

**2.5** The control systems in which the valve is installed must have proper safeguards – to prevent injury to personnel, or damage to equipment – should failure of system components occur.

**2.6** The upper limits of permitted pressure and temperature (depending on the housing and liner materials) must be observed. These limits are shown on the valve identification tag.

**2.7** The valve must not be operated until the following documents have been observed:  
> Declaration on EU Directives  
> IOM Manual (supplied with the product)

**2.8** Information provided in this manual is for standard valve configuration only. Specific instructions for non-standard materials of construction, temperature range, etc. please contact Kugelhahn Müller – see details on back cover.

**2.9** Based on many years of experience in the industry, Kugelhahn Müller can state without question the majority of all field problems are directly related to poor installation procedures.

## 3.0 VALVE IDENTIFICATION



### NOTICE

- > Ensure the box is not damaged externally.
- > Remove the valve from the packaging and check for any damage to the valve and its components during transit.
- > Report any damage or discrepancies immediately.
- > Every valve has an identification tag with the following data and must not be removed or covered, so that the installed valve remains identifiable.
- > Depending on the region, the valve identification tag may vary.

**3.1** All valves, actuators, or control products are provided with an identification tag that is unique to each device.

The following table is a representation of information that may be included.

Data	Identification	Description
Manufacturer	KM	KM = Kugelhahn Müller Refer to last page or website for contact details.
Valve Type	e.g. KM30	
Conformity	e.g. 2014/68/EU	
Number of the notified body	e.g. 0343	Notifying body according to EU-Directive (LRQA)
Serial Number	e.g. KEC000878	Serial number of the valve.
Size	e.g. DN 50	
Flange Drilling	e.g. PN 40	
TS	e.g. 180°C	maximum Service Temperature
PS	e.g. 10 bar	maximum Service Pressure
Body Material	e.g. 1.4571	Material number
Stem Material	e.g. EN 1.4542 EN 1.4462	
Ball Material	e.g. EN 1.4408	
Seat Material	e.g. PTFE	

## 4.0 INTENDED USE



### NOTICE

Failure to observe this section **<Intended Use>** constitutes gross negligence and releases the manufacturer, Kugelhahn Müller GmbH or Bray International, from its product liability.

In case of any questions, please contact the manufacturer.

See back page for contact details.

## 4.1 HAZARD-FREE USE

**4.1.1** The design features of this valve include a split body, two piece construction, allowing ease of maintenance without special tools. These valves feature a “free floating” ball. The ball is not fixed, but is free to move with the line pressure.

As a result of this feature, these valves are capable of tight shutoff with flow in either direction or dead-ended, regardless of the position of the valve in the line.

The downstream seat, opposite the pressurized side of a closed valve, must carry the load exerted by the line pressure on the ball, while the upstream seat is subject to little load or wear.

For this reason, it is sometimes possible to increase useful seat life by turning the valve end-for-end in the pipeline.

**4.1.2** This valve is exclusively intended for installation between flanges in a pipe system or with a welded joint on both sides, to shut-off or transport fluids within permissible pressure and temperature limits, or regulating their flow.

**4.1.3** The permissible upper limits of permitted pressure and temperature (depending on the housing and liner materials) must be observed.  
These limits are shown on the valve identification tag.

**4.1.4** The valve is operated either manually (handlever, gear with handwheel) or actuated (electric, pneumatic, hydraulic actuator).

**4.1.5** The valve is only suitable for operation in OPEN or CLOSED position. Operation at intermediate positions are not permitted.

## 4.2 HAZARDOUS ENVIRONMENTS (ATEX)



### WARNING

When using this product in hazardous environments, the national directives and laws which apply in your country for hazardous areas must be followed. The specifications of the examination certificate valid in country of operation must be also observed. Work may only be done on the valve in an explosion-proof environment without pressure, cooled down and free of fluid.



### CAUTION

A valve/actuator combination has the same ignition hazard as identified by the actuator manufacturer in the Ignition Hazard Assessment.

The operator shall observe the respective operating instructions.

Thus, the use of actuated valves in areas with potentially explosive atmospheres is permitted within the scope of intended use.

It is however necessary to ensure on site that the valve used in such a way has been included in the potential equilization measures of the system section and the user of an valve/actuator combination carries out an ignition hazard assessment of the system section.



### NOTICE

Use of the valve in a potentially Ex-atmosphere (ATEX) is only permitted, if expressly indicated by the customer.



## 5.0 QUALIFIED PERSONNEL



### NOTICE

Failure to follow these procedures <Qualified Personnel> could affect product warranty.

- 5.1** A **qualified person** (in terms of this document) is one who is familiar with the installation, commissioning, and operation of the device, and who has appropriate qualifications, such as:
- 5.2** > Is trained in the operation and maintenance of electrical equipment and systems in accordance with established safety practices and is able to properly assess and perform any task associated with the valve and can foresee or recognize any associated potential hazards and eliminate them as quickly as possible.
- 5.3** > Is trained or authorized to energize, de-energize, ground, tag, and lock electrical circuits and equipment in accordance with established safety practices.
- 5.4** > Is trained in the proper use and care of personal protective equipment (PPE) in accordance with established safety practices.
- 5.5** > Is trained in the commissioning, operation, and maintenance of equipment in hazardous locations — in cases where the device is installed in a potentially explosive (hazardous) location.

## 6.0 HANDLING REQUIREMENTS



### WARNING

A potential hazard exists with handling valves. Failure to handle valves properly may cause a valve to shift, slip or fall causing serious injury or death and/or equipment damage.

Caution must be taken during handling to avoid this equipment passing over workers, or over any other place where a possible fall could cause injury or damage.

For handling and/or lifting, the lifting equipment (fasteners, hooks, etc.) must be sized and selected while taking into account the product weight indicated in our packing list and/or delivery note. Lifting and handling must be performed only by qualified personnel, refer to **<Qualified Personnel>**.

Fasteners must be protected by plastic covers in sharp corner areas.

In all cases, local safety regulations must be respected.

## 6.1 PACKED VALVES

**6.1.1 Crates:** Lifting and handling of the packed valves in crates will be carried out by a fork lift truck, by means of the appropriate fork hitches.

**6.1.2 Cases:** The lifting of packed valves in cases will be carried out in the lifting points and in the center of gravity position which has been marked. The transportation of all packed material must be carried out safely and following the local safety regulations.

## 6.2 UNPACKED VALVES

**6.2.1** Lifting and handling of valves should be carried out by using appropriate means and observing the carrying limits. Handling must be carried out on pallets, protecting all machined surfaces to avoid any damage.

**6.2.2** With large bore valves, rigging the load must be carried out by using the appropriate tools to prevent the valve from falling or moving during the lifting and handling.

## 7.0 STORAGE



### NOTICE

The packaging is designed to protect the valve only during shipping.

If you are not installing the valve immediately after delivery, then you must store it according to these requirements.

Failure to follow these procedures **<Storage>** could affect product warranty.

## 7.1 SHORT-TERM STORAGE

**7.1.1** Short-term storage is defined as storage of valves to allow for project construction and will be installed within a relatively short amount of time (typically one to three months).

During short-term storage, the following is required:

**7.1.2** The preferred storage location is a clean, dry, protected warehouse. Do not expose the valve to temperature extremes.

**7.1.3** End protectors shall remain on the valve ends to prevent the entrance of dirt, debris, or insects/wildlife and should only be removed at the time of valve installation.

**7.1.4** The valve shall remain in the original shipping container with the original packaging materials. This packaging method will not protect valves that will be stored outside, uncovered, and unprotected.

**7.1.5** Storage of valves in an open, uncovered area is permissible, but requires provisions for inclement weather. The product must be elevated from the ground on a pallet, a shelf, or other suitable surface, and must be covered with a secure, waterproof tarp.



### CAUTION

**Do not** stack the valves on top of each other.

**7.1.6** Manually actuated valves may be stored in the vertical or horizontal position. For air or hydraulic actuated valves, the preferred orientation is with the valve and cylinder in the vertical position. Access ports should be secured to prevent unauthorized entry and prevent contamination.

## 7.2 LONG-TERM STORAGE

**7.2.1** **Long-term storage** is defined as storage of valves longer than three months. During long-term storage, the following is required:

**7.2.2** The storage location shall be a clean, dry, protected warehouse. Do not expose the valve to temperature extremes.



**7.2.3** End protectors shall remain on the valve ends to prevent the entrance of dirt, debris, or insects/wildlife and should only be removed at the time of valve installation.

**7.2.4** Product shall remain in the original shipping container with the original packaging materials.



## CAUTION

**Do not** stack the valves on top of each other.

**7.2.5** Manually actuated valves may be stored in the vertical or horizontal position. For air or hydraulic actuated valves, the preferred orientation is with the valve and cylinder in the vertical position. Access ports should be secured to prevent unauthorized entry and prevent contamination.

**7.2.6** Valves and equipment containing elastomers, including O-rings, must be stored in a climate-controlled warehouse according to SAE-ARP5316D requiring:

- > The ambient relative humidity to be less than 75%.
- > No exposure from direct ultraviolet or sunlight.
- > Protection from ozone generating equipment or combustible gases and vapors.
- > Storage at temperatures below 38°C (100°F), away from direct sources of heat. Preferred temperature range from 4°C to 29°C (40°F to 85°F). If a component is cooled below 15°C (59°F), the entire valve assembly should be allowed to rise above 20°C (68°F) before installing into service.
- > No exposure to ionizing radiation.

**7.2.7 Storage inspection — visual inspection** shall be performed on a semi-annual basis and results recorded. Inspection, as a minimum, shall include reviewing the following:

- > Packaging.
- > Flange covers.
- > Dryness.
- > Cleanliness.

## 8.0 LIFTING



### WARNING

A potential hazard exists with handling valves. Failure to handle valves properly may cause a valve to shift, slip or fall causing serious injury or death and/or equipment damage.



### CAUTION

Under no circumstances should the hand lever be used during this operation.

## 8.1 HANDLEVER

**8.1.1** The points below are for reference purposes only, use safe and proper lifting and support techniques. DO NOT lift valves with any adjoining pipe or other equipment attached. Lift with properly rated lifting equipment. Follow jurisdictional safety requirements.

Suggested lifting points are as shown below to lift valve assemblies that are in a horizontal orientation. Eye bolts in flange through holes can be used to lift the valve body.

## 8.2 VALVE WITH GEAR OPERATOR

For valves with gear operator, a sling or chain can be wrapped around the bevel gear actuator body, between the mounting plate and the input stem housing.

## 8.3 VALVE WITH PNEUMATIC ACTUATOR



### WARNING

Never lift the valve or valve package by the actuator, positioner, limit switch or their piping. When lifting a valve, be aware that the center of gravity may be above the lifting point. Therefore, support must be given to prevent the valve from rotating. Failure to do so can cause serious injury to personnel and damage to the valve and nearby equipment.

## 9.0 BILL OF MATERIAL

### 9.1 KMSP (O-Ring Sealing System)

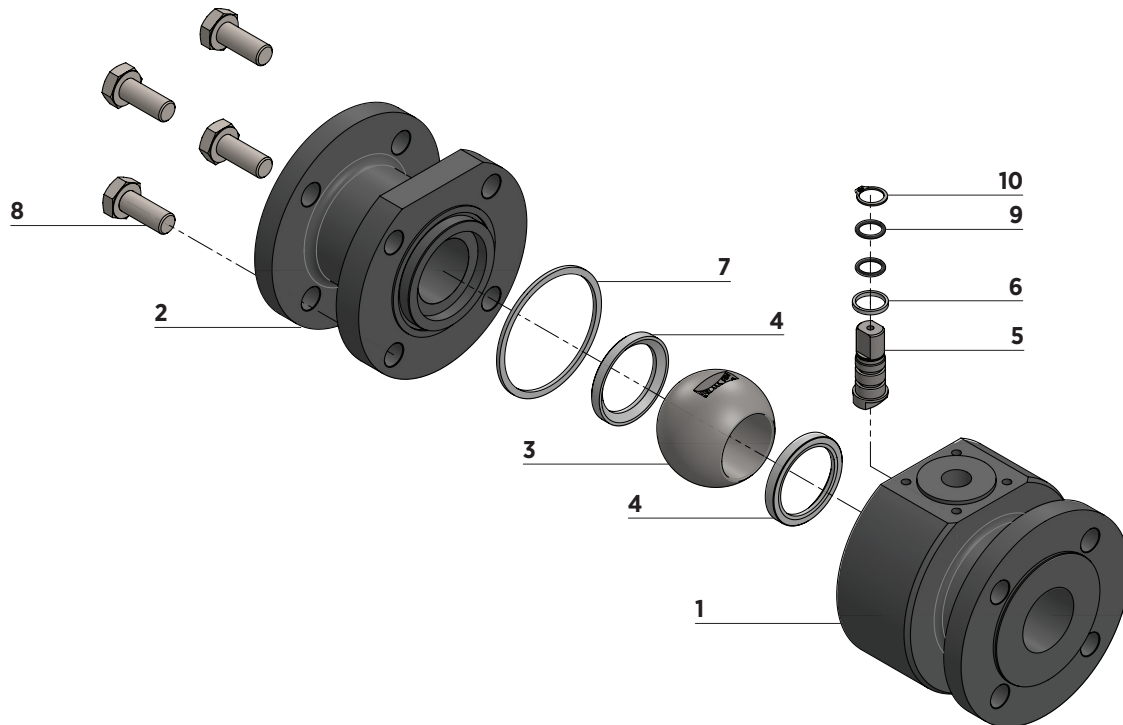

ITEM	DESCRIPTION
1	Body
2	End Cap
3	Ball
4	Seat
5	Stem
6	Thrust Washer
7	Body Gasket
8	Body Screw
9	O-Ring
10	Retainer Ring

## 9.2 KMHP (O-Ring Sealing System)

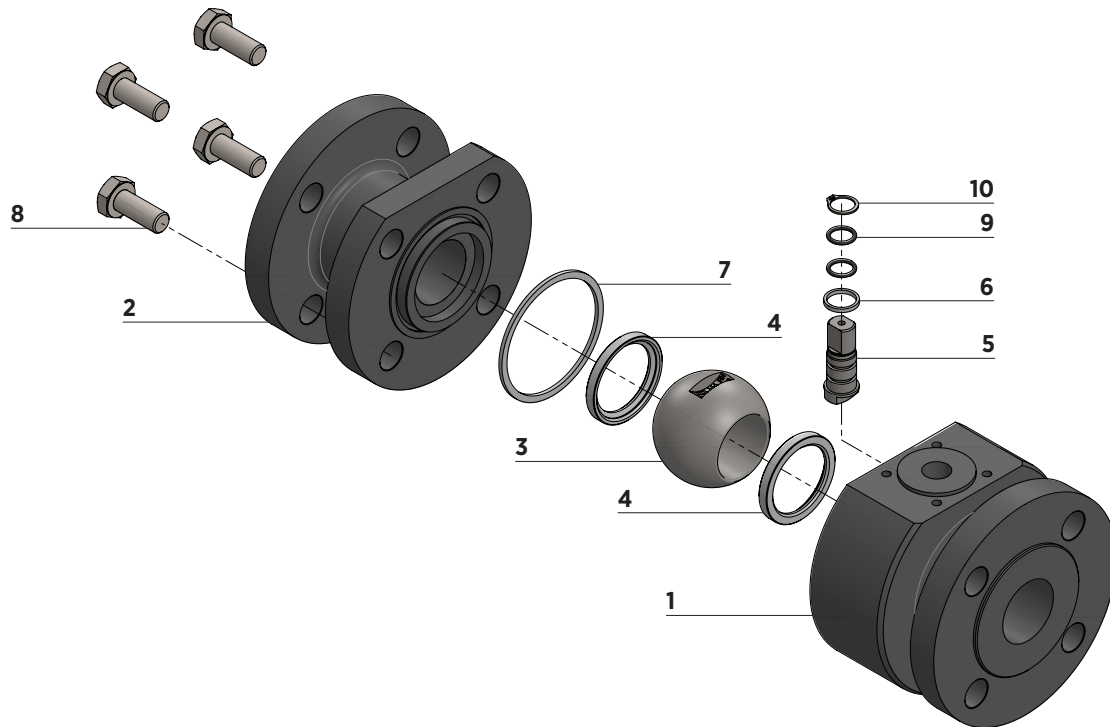

ITEM	DESCRIPTION
1	Body
2	End Cap
3	Ball
4	Seat
5	Stem
6	Thrust Washer
7	Body Gasket
8	Body Screw
9	O-Ring
10	Retainer Ring

## 9.3 KMHT (O-Ring Sealing System)

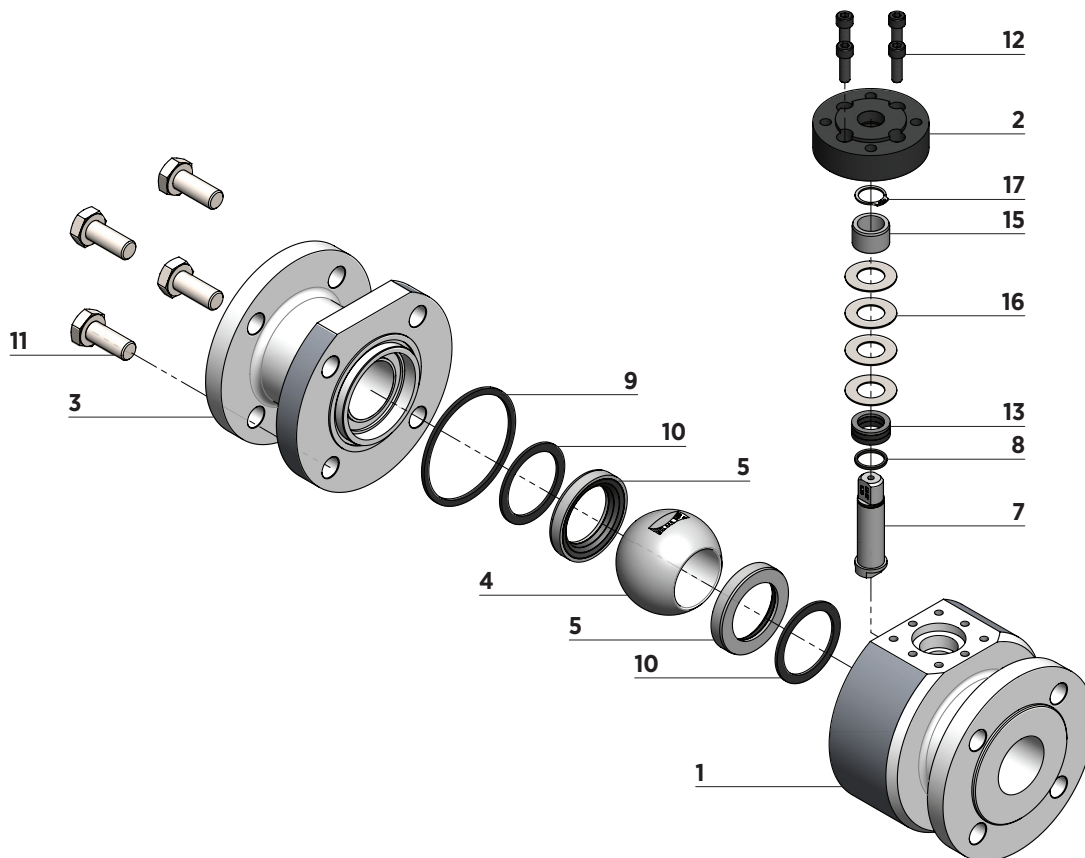

ITEM	DESCRIPTION
1	Body
2	Top Flange
3	End Cap
4	Ball
5	Seat
7	Stem
8	Thrust Washer
9	Body Gasket
10	Seat Gasket
11	Body Screw
12	Cap Screw
13	Packing
15	Packing Gland
16	Belleville Washer
17	Retainer Ring

## 9.4 KMPT (O-Ring Sealing System)

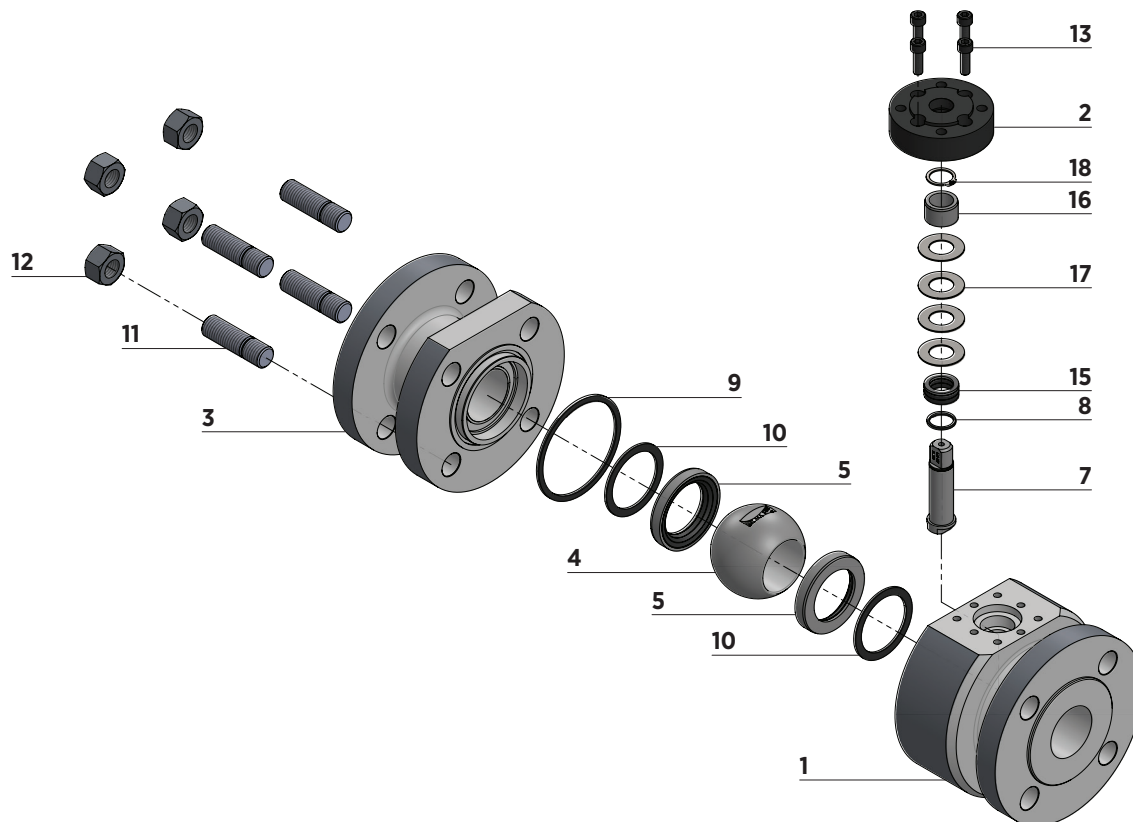

ITEM	DESCRIPTION
1	Body
2	Top Flange
3	End Cap
4	Ball
5	Seat
7	Stem
8	Thrust Washer
9	Body Gasket
10	Seat Gasket
11	Body Stud
12	Nut
13	Cap Screw
15	Packing
16	Packing Gland
17	Belleville Washer
18	Retainer Ring

## 10.0 INSTALLATION CONSIDERATIONS / SAFETY INSTRUCTIONS



### WARNING

- > Only qualified personnel, refer to section **<Qualified Personnel>** is allowed to install the valve.
- > Failure to follow this section **<Installation Consideration/ Safety Instructions>** could affect product warranty.
- > Verify line is depressurized before installing, removing, or repairing a valve or operator.
- > Do not pressurize the line without an operator on the valve.
- > Make sure that line is depressurized and drains are open/ monitored during installation.
- > The device generates a large mechanical force during normal operation.
- > Observe all applicable safety regulations for valves installed in potentially explosive (hazardous) locations.



### CAUTION

- > Risk of crushing the hand or fingers.
- > Do not operate a valve with actuator until it is installed.
- > Do not operate a valve installed at the open end of a pipe section.



### NOTICE

For the installation of valves in a pipeline, the same instructions apply as for the flange connection of pipes and similar pipeline elements.

Additional safety instructions may also be included in the instruction of the actuator assembly.

For transport to the installation site please ensure to observe the section **<Handling Requirements>**.

## 10.1 PIPING AND FLANGE COMPATIBILITIES (METAL FLANGES)

**10.1.1** This ball valve has been designed to be suitable for EN 1092 flange standard. Proper alignment of any valve between flanges is critical to good performance of the valve.

Stresses and displacements in the pipe system can result in an increased torque and leakage between valve body and connection ends. The distance between the pipe ends should correspond exactly to the dimensions of the valve.

The flange bolts must also be evenly tightened around the circumference of the valve, providing consistent flange compression of the molded profile on the gasket face.

## 10.2 VALVES WITH SPRING RETURN ACTUATORS

### 10.2.1 Fail Closed Assemblies

**10.2.1.1** If the valve is supplied with an actuator, the ball valve is shipped in the full closed position (as no air pressure is present to compress the springs and open the ball).

### 10.2.2 Fail Open Assemblies

**10.2.2.1** If the valve is supplied with an actuator, the ball valve is shipped in the full open position (as no air pressure is present to compress the springs and close the valve ball.) The sealing surface, or ball edge, is therefore exposed. Damage to that surface will cause premature seat failure.

## 10.3 VALVE LOCATION

**10.3.1** Ball valves should be installed if possible a minimum of 6 pipe diameters from other line elements, i.e., elbows, pumps, valves, etc. Of course, 6 pipe diameters are not always practical, but it is important to achieve as much distance as possible.

## 10.4 VALVE ORIENTATION



### NOTICE

The ball valve can be installed in any position, however Kugelhahn Müller does not recommend valves to be installed in an upside-down position.

**10.4.1** If a valve with a horizontal actuator stem is installed and the dimensions of the actuator are larger than those of the valve, the site manager shall decide whether the actuator requires a support on site.

## 11.0 INSTALLATION & COMMISSIONING



### WARNING

- > Ensure to follow the section **<Installation Consideration / Safety Instructions>** as well as section **<Installation & Commissioning>**.
- > Ensure that the selected materials of the wetted parts of the ball valve are suitable for the line media.
- > Do not install a valve whose approved pressure/temperature limits (= "rating" is not sufficient for the operating conditions.



### NOTICE

The valve is bidirectional, it can be installed in either direction and is also suitable for dead-end service.

After installation into a pipe system, these ball valves are exclusively used as intended to shutoff or transport fluids within the approved pressure and temperature limits. Refer to section **<Intended Use>**.

## 11.1 GENERAL

**11.1.1** The piping system and the control system for the actuator (if any) have been properly installed and are regularly checked. The wall thickness of the body of the ball valve is dimensioned in such a way that an additional load  $F_z$  of the usual order of magnitude ( $F_z = \pi/4 \cdot DN^2 \cdot PS$ ) is considered for such a properly installed piping system.

(PS = maximum permissible design pressure - refer to section **<Valve Identification>**)

**11.1.2** Transport the ball valve to the installation site in the protective packaging and only unpack it immediately before inserting it into the pipeline so that it remains protected from any contamination.

**11.1.3** Check the valve (and actuator) for transport damage. Do not install damaged ball valves or actuators.

**11.1.4** Ensure that only ball valves are installed whose pressure class, materials of the wetted parts, type of connection and flange dimensions meet the requirements of the operating conditions. Refer to corresponding marking of the ball valve.

**11.1.5** The connection data for the actuator unit must match the data of the control system. Refer to type plate on the actuator unit.

**11.1.6** Remove the protective caps on the connection ends of the valve immediately before installation.

**11.1.7** Even if the ball valves were transported in a clean environment, make sure to check the ball valve and the connecting pipeline for contamination or foreign matter prior to installation. Ensure the pipeline and pipe flange faces are clean. Any foreign material such as pipe scale, metal chips, welding slag, welding rods, etc., can obstruct ball movement or damage the ball or seat. In case of a negative result, thoroughly clean the valve and, most importantly, remove any hard foreign matter.



- 11.1.8** Use water or compressed air to clean the valves.  
Place the opening of the valve perpendicular to the floor and clean it. Make sure that the dust is completely removed from the opening. Next, check and clean the pipe opening and the connection point. There shall be no seams, rust spots or foreign matter to prevent blockage and leakage.
- 11.1.9** The flanges of the pipeline must be aligned with the flanges of the ball valve and have plane-parallel ends.
- 11.1.10** The ball valve shall be installed and operated as supplied by Kugelhahn Müller and the valve is properly connected to the systems.  
Modifications without consent of the manufacturer (except retrofitting of an actuator) are not permitted and relieve the manufacturer of their product liability.
- 11.1.11** When installing the ball valve (and the necessary seals) into an existing pipeline, ensure that the distance between the pipeline flanges is sufficient to prevent damage to the flange connection surfaces and the gaskets.  
Align the piping and then spread the pipe flanges a distance apart so as to permit the valve body to be easily dropped between the flanges without contacting the pipe flanges. However, in order to prevent any additional stresses in the pipeline when the flange connection is tightened, this distance should not be larger than required.
- 11.1.12** The valve package may be installed in any orientation. However, where possible, the actuator shall not be located directly below the ball valve. Leakage at the shaft could result in damage to the actuator. If a valve with a horizontal actuator stem is installed, it is at the discretion of the site manager to provide a suitable support.
- 11.1.13** Ensure necessary clearance is available in the pipeline system for actuation and for removal/re-installation for inspection and maintenance.
- 11.1.14** To connect an actuator unit to the control system, the relevant instructions apply
- 11.1.15** After installation is completed, perform a functional test:  
A ball valve with lever or gear/handwheel shall be easy to OPEN and CLOSE. Refer also to section **<Testing>**.
- 11.1.16** The following applies to an actuated ball valve:  
The valve must properly close and open according to the control commands. Any obvious malfunctions must be eliminated prior to commissioning. Also refer to section **<Troubleshooting>**.



## CAUTION

- > If retrofitting an actuator it must be confirmed that the torque, direction of rotation, angle of actuation and the **“OPEN” and “CLOSED” travel stop settings** are adjusted to suit the ball valve position. Connecting parts, such as brackets and adapters, shall be precisely aligned with the ball valve shaft. This shall ensure a parallel mounting of the actuator to the ball valve.
- > Actuators supplied together with ball valves are adjusted to the operating data specified in the order. The **“OPEN” and “CLOSED” travel stop settings** shall not be changed without the permission of the manufacturer.
- > **Only for ball valves with electric actuator:** Make sure that the actuator is switched off in the end positions by the signal of the limit switch. If the switch-off is triggered by the signal of the torque switch this signal should also be used to trigger a fault message. The fault must be rectified as quickly as possible, refer to section <Troubleshooting>. For further instructions, refer to the instructions of the electric actuator.

- 11.1.17** An actuator unit that has been retrofitted to a ball valve is adapted to the ball valve and correctly adjusted in its end positions. In particular in the open position.
- 11.1.18** Any use of an actuator for the ball valve in other than normal ambient atmospheres – especially in a potentially explosive -environment – has to be clarified with the manufacturer Kugelhahn Müller.
- 11.1.19** Ball valves installed in pipeline systems with operating temperatures  $> +50^{\circ}\text{C}$  or  $< -20^{\circ}\text{C}$  are to be protected against contact together with the pipeline section. Such insulation is not the responsibility of Kugelhahn Müller GmbH.
- 11.1.20** Ensure that the pressure of the ball valve corresponds to the operating conditions of the pipeline. Size and pressure ranges are indicated more precisely on our ball valves. Before installation, open and close the ball valve and check whether any problems occur during opening/closing and whether the ball is in the correct position.

## 11.2 VALVE-ACTUATOR-ASSEMBLY



### CAUTION

- > Actuators supplied together with ball valves are adjusted to the operating data specified in the order. The **“OPEN” and “CLOSED” travel stop settings** shall not be changed without the permission of the manufacturer.
- > **Only for ball valves with electric actuator:** Make sure that the actuator is switched off in the end positions by the signal of the limit switch. If the switch-off is triggered by the signal of the torque switch this signal should also be used to trigger a fault message. The fault must be rectified as quickly as possible, refer to section <Troubleshooting>. For further instructions, refer to the instructions of the electric actuator.



### NOTICE

- > Do not use the valve (and actuator) as a “stepladder”.
- > Do not apply external loads to the valve (and actuator); this may damage or destroy the ball valve.
- > It is recommended to support actuation, especially when larger or heavier than the valve it is mounted to, when the valve is installed in a vertical line or when the stem is oriented in any position other than vertical. Supporting the actuator will remove unnecessary side loads from the valve stem, prolonging the service life of the seal.

## 11.3 PRESSURE TESTING & COMMISSIONING



### WARNING

Ball valves have a cavity between the ball and the valve body in which small amounts of water from the pressure test accumulate: To remove this water, e.g. by drying the pipe section, the ball valve must remain in an intermediate position (e.g. half-open) while the pipe section dries.



### NOTICE

Prior to commissioning, flush the system to remove dirt. Ensure that the ball valve is open during the entire flushing process; do not operate the ball valve until cleaning is complete.

**11.3.1** Kugelhahn Müller has already performed the required tests on each finished valve in accordance with the European Standard EN 12266.

**11.3.2** The following restrictions and notes apply if a pressure test of the pipe section is required together with the installed ball valve:

**11.3.3** > To remove any foreign matter, thoroughly flush newly installed piping systems before closing them for the first time.

**11.3.4** > When the valve is in open position, the test pressures shall not exceed the value 1.5 x design pressure (PN or PS) as per the valve marking.

**11.3.5** > When the ball valve is in closed position, the maximum test pressure to be applied = 1.1 x (PN or PS).

- 11.3.6** > If a leakage occurs at a valve, observe the section  
<Troubleshooting>.

## 11.4 VALVE REMOVAL



### WARNING

- > Before the ball valve is removed from the pipeline, the pressure in the pipeline must be completely relieved so that the line media does not escape from the pipeline in an uncontrolled manner.
- > Line media may leak from the pipeline or from the ball valve.
- > If a ball valve used for dead-end service in a pressurised line has to be opened, due care must be used to prevent the media splashing out from causing any damage.



### CAUTION

In completely open/closed position, residues of the media remain in the ball valve.

- > Drain the valve body completely
- > Place the ball in intermediate position immediately prior to removal
- > Observe the same safety instructions as for the piping system and the (electrical/pneumatic) supply system/control system.



### NOTICE

Care should be taken to avoid scratching or damaging serrated flange face. These valves are heavy!

- 11.4.1** Securely interrupt the power supply if applicable.
- 11.4.2** Open the valve and drain the pipeline section.
- 11.4.3** Remove flange bolts and nuts and lift valve from line for servicing.
- 11.4.4** Make sure that the ball surface is bright and free from damage.
- 11.4.5** If the valve is to be stored, observe the instructions section <Storage>.



### WARNING

Never pick up the valve by the actuator or operator mounted on top of the valve.

Refer to sections <Handling Requirements> and <Lifting>.

## 12.0 OPERATION AND MAINTENANCE



### WARNING

- > Verify line is depressurized before installing, removing, or repairing a valve or operator.
- > Do not pressurize the line without an operator on the valve.
- > After completing any alterations or maintenance procedures, the product must be tested to confirm performance requirements.
- > When the process fluid is hazardous, thermal (hot or cold), or corrosive, take extra precautions.
- > Always wear protective clothing and equipment to safeguard the eyes, face, hands, skin, and lungs from the particular fluid in the line.
- > **For ball valves used in dead-end service:**  
During normal operation, especially with gaseous, hot and/or hazardous media, a blind flange must be installed to the open end of the valve or the ball valve must be securely and permanently locked in the "CLOSED" position.



### CAUTION

- > Disconnect electrical, pneumatic, and hydraulic power before servicing actuator or automation components.

#### **Risk of crushing the hand or fingers:**

- > Do not operate a valve with actuator until it is installed.
- > Do not operate a valve installed at the open end of a pipe section.



### NOTICE

- > Any modification or use of unauthorized parts voids any and all warranty considerations.
- > Note assembly positions before removal.

## 12.1 NORMAL OPERATION



### NOTICE

In EN 12570: Manual forces, standard values are defined according to lever length or handwheel-Ø.

**12.1.1** Operation of the valve is done by turning the handle a 1/4 turn (90 degree turn). clockwise (CW) to close, counter clockwise (CCW) to open.

#### **12.1.2 Valve Open Position**

The handle is parallel with the pipeline

#### **12.1.3 Valve in closed Position**

The handle is perpendicular to the pipeline.

**12.1.4** Normal manual force is sufficient to operate ball valves designed for manual operation. The use of lever extensions to increase the operating torque is not permitted.

**12.1.5** Operate actuated ball valves via the signals of the control system. Ball valves supplied with actuator by manufacturer Kugelhahn Müller are precisely adjusted and shall not be changed as long as the valve is functioning properly.



**12.1.6** Valves with actuators should be checked for actuator-valve alignment. Misalignment will result in high operational torque and damage to valve stem and seals.

## **12.2 MAINTENANCE**

**12.2.1** Ball valves do not require regular maintenance.

However, when checking the pipeline section at suitable intervals make sure that there is no leakage at the flange and screw connections of the valve body and at the stem seal.

In case of leakage and repairs see **<Troubleshooting>**.

It is recommended to operate ball valves that permanently remain in the same position once or twice per year.

**12.2.2** Subject to regular visual inspection of the pipe section, the valve does not require special maintenance.

**12.2.3** For actuators (if available), observe the respective manufacturer's instructions.

**12.2.4** If the valve is used in corrosive/abrasive media and/or at the threshold of its pressure/temperature limits and/or subject to (very) frequent operation, the ball valve should be inspected regularly at suitable intervals, but at least once or twice per year.

In case of faults refer to section **<Troubleshooting>**.

**12.2.5** If components require replacement, the valve must be removed from the line. Refer to section **<Valve Removal>**

## 13.0 DISASSEMBLY/ASSEMBLY INSTRUCTIONS



### NOTICE

- > Failure to follow this section <Disassembly/Assembly> could affect product warranty.



### WARNING

- > Verify line is depressurized before disassembly.
- > Valve should be cycled to assure there is no pressure trapped in valve cavity.
- > Ball valves can trap pressurized media when closed.
- > Flush line with valve in the half open position to remove hazardous media.
- > After completing any alterations or maintenance procedures, the product must be tested to confirm performance requirements.
- > When the process fluid is hazardous, thermal (hot or cold), or corrosive, take extra precautions.
- > If the valve has been used to control hazardous media, it must be decontaminated before disassembly.
- > Always wear protective clothing and equipment to safeguard the eyes, face, hands, skin, and lungs from the particular fluid in the line.

## 13.1 DISASSEMBLY: STEM AND SEAL REMOVAL

**13.1.1** Remove the handle, gear operator, or power actuator from actuator mounting flange.

**13.1.2** Loosening of the body screw on the ball valve using a suitable wrench; subsequently removing the end cap.

**13.1.3** Remove body seal.

**13.1.4** To take out the ball, rotate stem so ball is in fully closed position. Lift ball from body, using a strap and lift device, if necessary



### CAUTION

Extreme caution should be taken to avoid damage to the ball.

**13.1.5** Take out other seat.

**13.1.6** Stem must be removed from inside the body - a tap on the top of the stem should loosen it. The thrust washer should come out with the stem. Then remove the stem packing.

## 13.2 VISUAL INSPECTION

**13.2.1** Clean and inspect metal parts.

**13.2.2** It is not necessary to replace the ball and stem unless the seating surfaces have been damaged by abrasion or corrosion.

**13.2.3** We strongly recommend replacement of all soft parts whenever the valve is disassembled for reconditioning to protect against subsequent leakage after valve reassembly.

## 13.3 ASSEMBLY



### CAUTION

Extreme care must be exercised during the adjustment of body screw to make sure that body screws are fully engaged. There should be at least one stud thread exposed beyond the flange on the body side and beyond the nut on the cap side.



### NOTICE

The valve may be assembled and operated dry where no lubricants are allowed in the system; however, a light lubrication of mating parts will aid in assembly and reduce initial operating torque. Lubricant used must be compatible with the intended line fluid.

- 13.3.1** Install one seat in the body seat cavity with the spherical curvature facing the ball.
- 13.3.2** Install the thrust washer and O-rings onto the stem in the correct position, then insert the stem assembly through the housing in the upward direction.
- 13.3.3** Install handle and handle retainer nut.
- 13.3.4** Turn the handle CW (clockwise) to the CLOSED position.
- 13.3.5** Line up the ball slot with the stem tang and slide the ball into position.
- 13.3.6** Turn the handle CCW (counter-clockwise) to the OPEN position to hold the ball in place.
- 13.3.7** Install the remaining seat into end cap seat pocket.
- 13.3.8** Put body seal gasket into shoulder counter bore at flange in valve body.
- 13.3.9** Put end cap back into body and line up end flange.  
Because the body flange bolt pattern is different from the line flange bolt pattern, it is possible to assemble the valve which the bolt holes in the line flanges don't line up. Be certain to align end flanges bolt holes to straddle valve center lines.



### NOTICE

Be careful not to damage body seal when assembling end into body.

- 13.3.10** Install body screws and tighten in a crossing pattern.
- 13.3.11** Cycle the valve slowly, with a gentle back and forth motion, to build gradually to the full quarter turn. By cycling slowly, the seat lips will assume a permanent seal shape against the ball. A fast turning motion, at this point, may cut the seats before they have a chance to form the proper seal.
- 13.3.12** Test the valve, if possible, prior to placing the valve back into line position.

## 13.4 TESTING



### WARNING

If not properly secured, the valve can become separated from the pressure source, resulting in possible injury. Always join the valve to flanges of the same pressure rating and secure with a full set of flange bolts.

- 13.4.1** Apply test flange to the valve with full set of flange bolts and a suitable gasket. Orient the valve with the bore in the vertical position and the seat being tested facing up.
- 13.4.2** Introduce 6 bar.  
Partially cycle the valve, under pressure, and then slowly close to make sure the cavity is pressurized (use hearing protection).  
Pour water into the upper port to cover the ball and visually check for bubbles.  
If bubbles appear, pour the water out, cycle the valve several times and recheck.  
To check for leakage in the other port, reverse the valve and introduce air pressure to the port just checked.
- 13.4.3** Check stem seal at this time by coating the gland area with a soapy water solution.  
If leakage occurs, tighten stem seal just until leakage stops.

## 14.0 TROUBLESHOOTING



### NOTICE

- > Only original parts from Kugelhahn Müller GmbH may be installed.
- > If, after disassembly, it is found that the body and/or internal parts are not sufficiently resistant to the media, appropriate components made of suitable materials should be selected in consultation with Kugelhahn Müller GmbH.
- > If it is assumed that a ball valve which has been disassembled for maintenance / repair is correctly reassembled before commissioning and the subjected to a pressure test with water in accordance with **<Pressure Testing & Commissioning>** is carried out. The instructions provided by Kugelhahn Müller include a detailed information for reassembly.
- > Kugelhahn Müller GmbH does not accept any responsibility for the product if wear parts not tested and approved by Kugelhahn Müller GmbH are used.
- > Kugelhahn Müller GmbH does not accept any responsibility for the product if maintenance instructions are not followed during maintenance.

FAULT	MEASURES FOR RECTIFICATION
Leakage at flange connection to pipeline	When a leakage occurs in this area, first retighten flange connection. If this does not eliminate the leakage, remove the valve. Observe section <b>&lt;Installation considerations/Safety instructions&gt;</b> and replace the flange gasket.
Leakage at the connection of the valve body parts	<ul style="list-style-type: none"> <li>&gt; Use a torque wrench to retighten screws as indicated in the section <b>&lt;Assembly instructions&gt;</b>.</li> <li>&gt; If this does not eliminate the leakage, remove the valve.</li> <li>&gt; Observe section <b>&lt;Safety instructions&gt;</b> and replace the flange gasket.</li> <li>&gt; Observe section <b>&lt;Valve Removal&gt;</b> and replace the body gasket.</li> <li>&gt; Request spare parts and respective instructions from the manufacturer.</li> <li>&gt; Follow section <b>&lt;Assembly instructions&gt;</b></li> </ul>
Leakage at stem seal (O-Ring Sealing System only) or excessive leakage in CLOSED position	<ul style="list-style-type: none"> <li>&gt; Repair required.</li> <li>&gt; Request spare parts and respective assembly instructions from Kugelhahn Müller.</li> <li>&gt; Disassembly according to section <b>&lt;Valve Removal&gt;</b>.</li> <li>&gt; Assembly according to section <b>&lt;Assembly instructions&gt;</b>.</li> <li>&gt; Observe section <b>&lt;Installation considerations/Safety instructions&gt;</b>.</li> </ul>
Malfunction	<ul style="list-style-type: none"> <li>&gt; Check actuator unit and control commands.</li> <li>&gt; If actuator and control system are OK, remove valve.</li> <li>&gt; Observe section <b>&lt;Installation considerations/Safety instructions&gt;</b> and check the valve.</li> <li>&gt; Repair is required if ball valve is damaged – see above.</li> <li>&gt; Request spare parts and respective instructions from Kugelhahn Müller.</li> </ul>

## 15.0 RETURN MATERIAL AUTHORIZATION



### NOTICE

Materials must be cleaned and sanitized prior to return. MSDS sheets (Material Specification Data Sheets) and Declaration of Decontamination are required.

Product information is provided on identification tag attached to device.

**15.1** All products that are returned require a Return Material Authorization (RMA). Contact a representative to obtain authorization and shipping instructions.

**15.2** The following information must be provided when submitting RMA.

- > Serial number
- > Part number
- > Month and year of manufacture
- > Actuator specifics (if applicable)
- > Application
- > Media
- > Operating temperature
- > Operating pressure
- > Total estimated cycles (since last installation or repair)



---

## APPENDIX A: CONFORMITY OF EU DIRECTIVES

The current version of the Declaration of Conformity according to the applicable EC/EU Directives can be provided upon request.

---

SINCE 1979 KUGELHAHN MÜLLER IS KNOWN FOR ITS HIGHEST QUALITY STANDARDS, CUSTOMER PROXIMITY AND RELIABLE DELIVERY.

CONVINCE YOURSELF.

VISIT **KH-M.DE** AND LEARN MORE.

## HEADQUARTERS

### **Kugelhahn Müller GmbH**

Halskestraße 14

D-47877 Willich

T.: +49 (0) 2154 8875 200

info@kh-m.de

All statements, technical information, and recommendations in this bulletin are for general use only. Consult Kugelhahn Müller GmbH for the specific requirements and material selection for your intended application.

The right to change or modify product design or product without prior notice is reserved.

Patents issued and applied for worldwide.

© 2026 KUGELHAHN MÜLLER GMBH. ALL RIGHTS RESERVED

EN\_KM\_IOM\_SP-HP-HT-PT\_20260619

---



**KUGELHAHN MÜLLER**  
A BRAY COMPANY

**YOUR SPECIALIST FOR BALL VALVES**

**KUGELHAHN-MUELLER.DE**