

---

**SERIES 942**

# **VORTEX BREAKER KNIFE GATE VALVES FOR RECYCLE/REJECTS**

4" to 12" 150psi (10bar)



---

**Bray**<sup>®</sup>

## FEATURES & BENEFITS

### DESIGN FEATURES

The Bray Series 942 is engineered for on/off service and isolation of pulp and paper recycle and rejects applications. The 942 offers superior performance in demanding, high-cycle services that require shearing capabilities such as cyclone separators and recycle high density cleaners.

Bray Series 942 heavy duty is an engineered solution featuring a standard replaceable Vortex Breaker designed to interrupt cyclonic flow formation which causes premature gate damage.

- 1 Pneumatic actuator sized and designed for high cycle applications.
- 2 Clevis design and horizontal bolting stabilizes gate ensuring proper alignment and reducing failure points commonly found in knife gate valves.
- 3 HD packing system using a copper scraper and high performance packing, including machined packing chamber, live-loaded packing gland to assure extended cycle life and minimizes thrust of actuation.
- 4 Abrasion and impact resistant 17-4PH H-1025 gate.
- 5 Standard Vortex breaker is designed to disrupt cyclonic flow formation of reject materials (staples, wire, nails, sand, etc) A36 with tungsten carbide coating provides extended service life.
- 6 Purge ports in seat and chest area allow full flushing capability while cycling.
- 7 Cast yoke superstructure robust design engineered for heavy duty actuators.

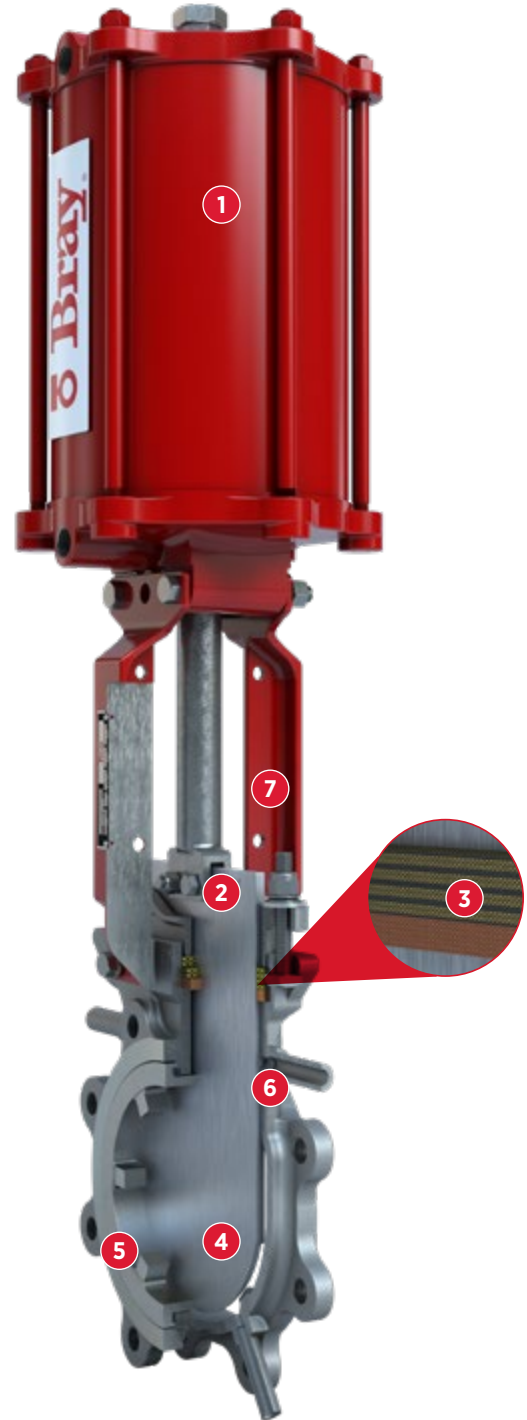

---

### APPLICATION

- > Knotter, Rejects, Pulpers, Scavengers and Cyclone Cleaners

Series 942 Lug Style



**RECYCLE PROCESS**

1. A & B are closed while system fills
2. A opens and rejects media drops through Valve A into Valve B
3. Quality pulp flows upward to the process and reject material falls down for recycling
4. Valve A closes and Valve B opens discharging rejects until empty
5. Valve B then closes

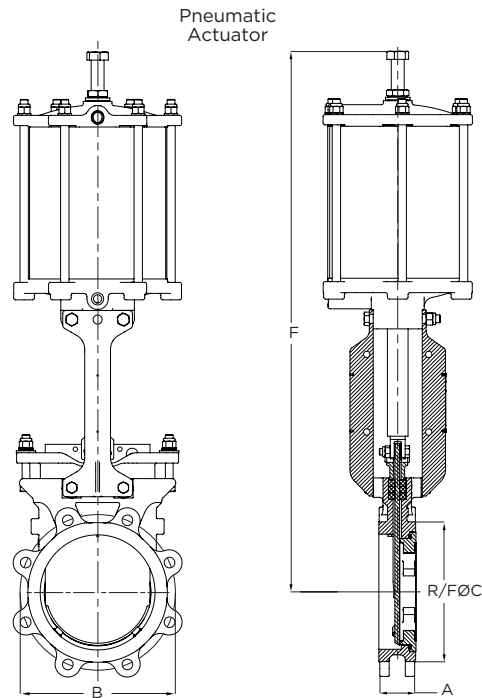

**TECHNICAL SPECIFICATIONS**

<b>Size Range</b>	NPS 4 to 12   DN 100 to 300
<b>Body Style</b>	Single piece   Lug
<b>Pressure Rating</b>	4-12 150psi   100-300mm 10 bar
<b>Drilling</b>	ASME B16.5 CL150
<b>Face to Face</b>	MSS SP-81
<b>Certification</b>	CE/PED
<b>Design Standard</b>	MSS SP-81
<b>Testing Standard</b>	MSS SP-151

**STANDARD CONSTRUCTION**

<b>Body</b>	CF8M (316)
<b>Gate</b>	17-4PH H-1025
<b>Seat</b>	Hard Faced
<b>Gland</b>	304
<b>Packing</b>	High Performance Aramid packing with bottom copper wiper
<b>Topworks</b>	CS
<b>Vortex Breaker</b>	A36 with Tungsten Carbide overlay

**DIMENSIONS (Inches)**

NPS	A	B*	R/FØC	F
4	2.00	7.50	6.19	25.39
6	2.25	9.50	8.50	31.65
8	2.75	11.75	10.62	38.74
10	2.75	14.25	12.75	44.21
12	3.00	17.00	15.00	51.22

**WEIGHT (lbs)**

PNEUMATIC ACTUATOR
53
84
121
212
313

**DIMENSIONS (Millimeters)**

DN	A	B*	R/FØC	F
100	51	190.5	158	645
150	57	241.3	216	804
200	70	295.5	270	984
250	70	362.0	324	1123
300	76	431.8	375	1301

**WEIGHT (kg)**

24
38
55
96
142

**NOTE**

1 Dimensions are approximate and subject to change. Consult factory for certified drawings.

\* In conformance with ASME B16.5, Class 150 for sizes NPS 4 (DN100) through NPS 12 (DN300.)

---

SINCE 1986, BRAY HAS PROVIDED FLOW CONTROL SOLUTIONS FOR A VARIETY OF INDUSTRIES AROUND THE WORLD.

VISIT **BRAY.COM** TO LEARN MORE ABOUT BRAY PRODUCTS AND LOCATIONS NEAR YOU.

**HEADQUARTERS**

**Bray International, Inc.**

13333 Westland East Blvd.

Houston, Texas 77041

Tel: +1.281.894.5454

All statements, technical information, and recommendations in this bulletin are for general use only. Consult Bray representatives or factory for the specific requirements and material selection for your intended application. The right to change or modify product design or product without prior notice is reserved. Patents issued and applied for worldwide. Bray® is a registered trademark of Bray International, Inc.

© 2022 BRAY INTERNATIONAL, INC. ALL RIGHTS RESERVED. BRAY.COM

KG Series 942 20220922

---



**THE HIGH PERFORMANCE COMPANY**

**BRAY.COM**