

SERIES F15 EN FLANGED BALL VALVES

DN15 - DN300
PN10, PN16, PN25, PN40



FlowTek[®]
Subsidiary of BRAY INTERNATIONAL, Inc.

BRAY.COM

THE HIGH PERFORMANCE COMPANY

FLOW-TEK'S F15 EN

Flanged series ball valves feature a floating ball valve design for low torque and increased cycle life.

Ball supports come standard in larger sizes ensuring proper ball and seat alignment for reduced wear.

These rugged ball valves are ideal for industrial applications and accurate flow control requirements can be achieved with the optional V-Port balls.

SPECIFICATION

Port	Full Port
Size Range	DN15 - DN300
Body Style	2 Piece
Temperature Range	-46°C to +343°C
Pressure Rating	PN10, PN16, PN25, PN40
Body Materials	Stainless Steel (1.4408) Carbon Steel (1.0619)
Seat Materials	Standard: TFM 1600 Optional: TekFil®, PEEK, UHMWPE, RPTFE, Metall, Cavity Fillers

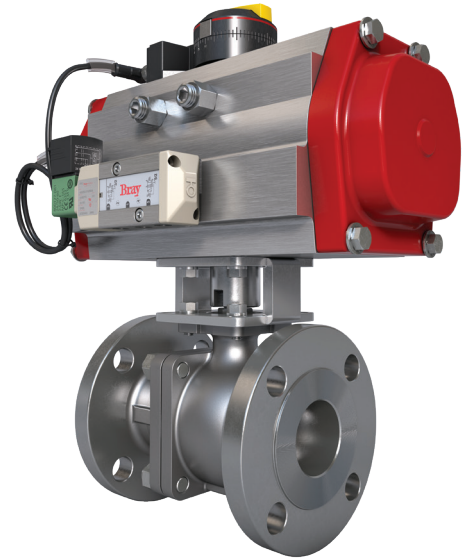

STANDARDS & CERTIFICATIONS

Valve Design	EN 12516, ISO 17292
End Flanges	EN 1092-1
Face-to-face	EN 558-1, DIN 3202
Top flange	ISO 5211
Testing	EN 12266, ISO 5208
Fire Safe	API 607

Internal Wetted Parts	NACE MR0175
Pressure Equipment Directive	2014/68/EU
ATEX Conformance	2014/34/EU
Russian Federation Certificate	EAC
Safety Integral (SIL)	IEC 61508 SC 3
Fugitive Emissions	EN 15848-1, TA-Luft VDI 2440

SPECIAL OPTIONS

Cavity Fillers
Spring Return Handles
Vented Balls
Characterised Balls

Media Containment Unit
Polished Internals
Special Cleaning
Silicone Free



SEAT SELECTION

TFM 1600¹ is our standard seat material.

Optional seat materials provide versatile performance in a range of applications.

- > RPTFE
- > Stainless Steel/PTFE (50/50)
- > UHMWPE
- > Virgin PTFE
- > PEEK²
- > Tek-Fil^{®3}
- > Metal Seats⁴
- > Cavity fillers

¹TFM 1600 seats offer the exceptional chemical resistance of PTFE plus lower porosity and permeability, improved temperature range and reduced valve torques.

²PEEK seats offer high pressure/temperature capability.

³Tek-Fil[®] seats offer reduced torque in high temperature, high cycle and steam service applications.

⁴ Available on request.

PRESSURE/TEMPERATURE

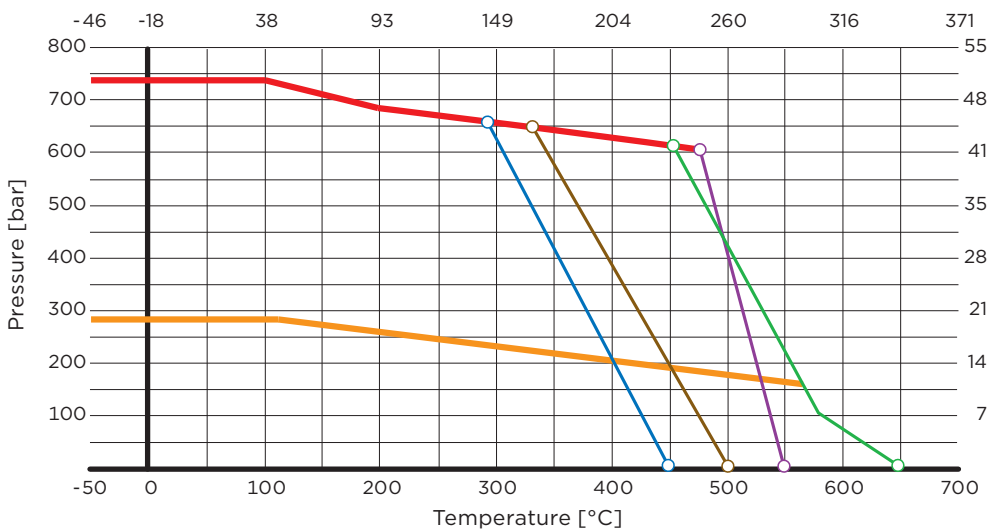

LEGEND

- PN 10 & 16
- PN 25 & 40
- RPTFE
- TFM 1600 & 50/50
- PEEK
- Tek-Fil

Note:

Carbon steel valves limited to -20°F (-29°C)

STEAM SERVICE PRESSURE RATINGS

PN	TFM 1600		TEK-FIL [®]		PEEK	
	bar	°C	bar	°C	bar	°C
10	7	170	7	185	7	170
16	10	185	11	187	11	187
25	10	195	17	206	17	206
40	10	185	17	220	23	220

Note:

Vacuum service to 1,013 mbar.

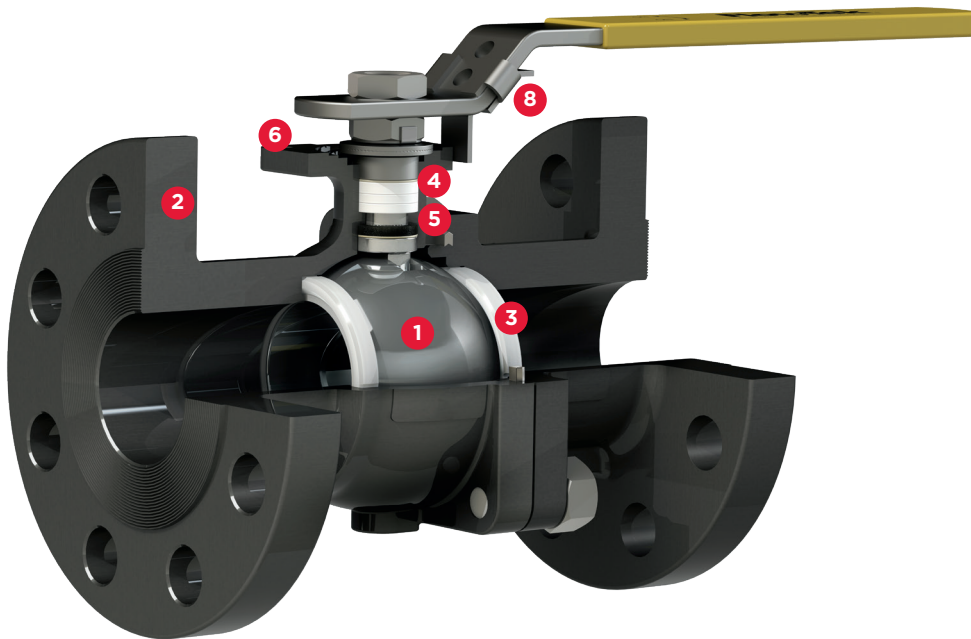

V-PORT BALLS

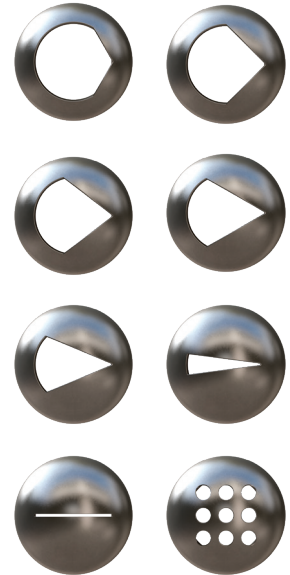

- 1 BALL** | Flow-Tek balls are precision machined and mirror finished for bubble-tight shut off and low operating torque. As an added safety feature, a hole in the stem slot of each ball equalises pressure between the body cavity and the line media flow.
- 2 BODY** | DN15 – DN100 valve bodies are investment cast and solution annealed/normalised for the highest quality and additional strength. All body castings are marked with a foundry heat number for full traceability. Carbon steel bodies are phosphate coated to increase corrosion resistance.
- 3 SEAT** | The seat design ensures bi-directional, bubble-tight sealing whilst maintaining low operating torque. All resilient seats feature relief slots on seat outer diameter clearance to relieve pressure past the upstream seat. Seats also have positive pre-loading to ensure low pressure/vacuum sealing.
- 4 STEM ASSEMBLY** | Heavy duty, high quality stems with double “D” connections to ball and operator mounting. Stem and ball design ensure positive contact. All Flow-Tek stems are internal entry and blow-out proof for maximum safety.

- 5 STEM SEALS** | A thrust washer and thrust washer protector combine to provide the primary seal, reduce torque and prevent galling. Adjustable stem packing creates a secondary seal between the stem and body. The stem packing is composed of multiple RPTFE V-rings as standard; graphite stem packing is standard on all fire safe valves.
DN15 – DN50 features Flow-Tek’s Smart Stem. This stem is self-adjusting due to its Belleville washers allowing it to compensate for environmental changes and wear. DN65 – DN300 valves utilise an independent packing gland which can be easily adjusted without removing mounting hardware or operator. The packing gland is contoured to uniformly distribute the load across the packing.
- 6 TOP FLANGE** | The integrally cast top flange ensures actuator mounting to eliminate unwanted actuator movement during high cycle or continuous duty applications. Actuation equipment can be easily and safely removed while the valve is under full line pressure. The mounting patterns are offered in accordance with ISO 5211.

7 FIRE SAFE

These ball valves with graphite stem seals have been fire tested and meet the API 607 standards. In the event of a fire, after heat destroys the primary resilient seat, the ball makes contact with the secondary metal seat, forming a secure seal. The body seal, composed of stainless steel and graphite wound into a spiral, prevents external leakage. Graphite stem rings prevent stem leakage.

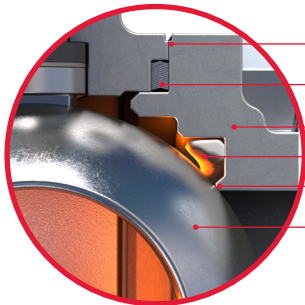

- Metal-to-Metal Contact
- Body Seal
- Valve Body
- Burned Seat
- Secondary Metal Seat
- Ball

8 LOCKING DEVICE

All manually operated valves feature a locking device to prevent unintended movement of ball position. Valves sizes DN15 - DN50 feature a safety trigger that locks the handle in the open or closed position. The handle lock can also be bypassed, if needed, with a small bolt through the handle in the release position.

Sizes DN65 - DN300 feature a travel stop plate that can be secured in the open or closed position with a padlock.

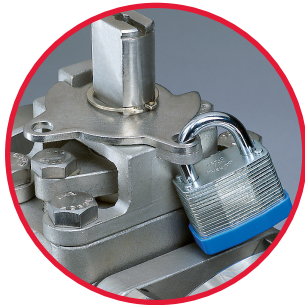

SMART STEM | DN15 - DN50

Flow-Tek's interchangeable family of valves feature strong, large diameter stems with live-loaded, self-adjusting seals. Belleville washers are utilised to automatically compensate for changes in temperature and wear. Manual adjustments which can cause damage to the seal and seat are not required. The assembly is secured by a saddle-type lock washer which prevents stem nuts from unthreading in high cycle automation applications



BALL SUPPORT | DN150 - DN300

As standard, larger diameter feature a trunnion-type ball support. This support helps to maintain continuous contact between the ball and seats, preventing seat deformation and blow-by due to the weight of the ball. The results are less seat wear, lower torque, and longer service life.

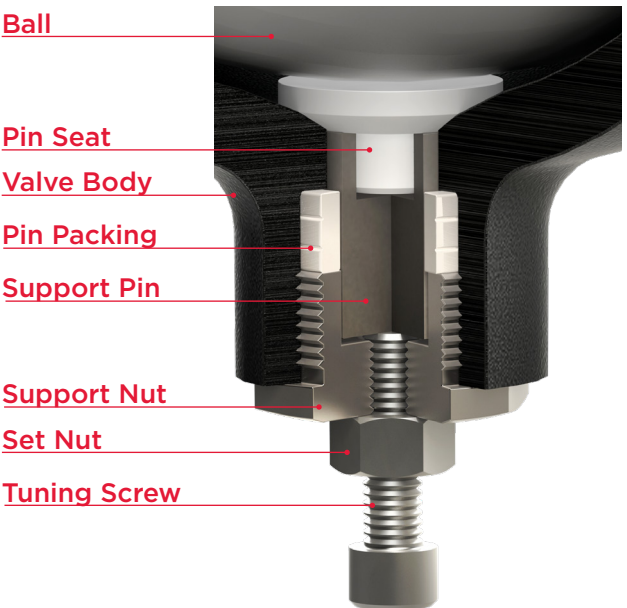

ITEM	DESCRIPTION	QTY	STAINLESS STEEL	CARBON STEEL
1	Body	1	EN 1.4408	EN 1.0619
2	End Cap	1	EN 1.4408	EN 1.0619
3	Ball	1	EN 1.4401	EN 1.4401
4	Seat	2	TFM 1600	TFM 1600
5	Stem	1	EN 1.4401*	EN 1.4401*
6	Body Seal	1	Spiral Wound (316 with Graphite)	Spiral Wound (316 with Graphite)
7	Body Nut	**	A2-70/Stainless Steel 304	Alloy Steel
8	Body Stud	**	A2-70/Stainless Steel 304	Alloy Steel
9	Anti-Static Device (Shown on page 3)	2	Stainless Steel 316	Stainless Steel 316
10	Packing Protector	1	PEEK	PEEK
11	Thrust Washer Protector	1	PEEK	PEEK
12	Thrust Washer	1	Tek-Fil®	Tek-Fil
13	Stem Bearing	1	15% RPTFE	15% RPTFE
14	Stem Packing	***	RPTFE or Graphite	RPTFE or Graphite
15	Packing Gland	1	EN 1.4301/ Stainless Steel 304	EN 1.4301/ Stainless Steel 304
16	Packing Follower	1	EN 1.4408	EN 1.0619
17	Gland Bolt	2	A2-70/Stainless Steel 304	Alloy Steel
18	Belleville Washer	2	Stainless Steel 301	Stainless Steel 301
19	Tab Lock Washer	1	Stainless Steel 304	Stainless Steel 304
20	Travel Stop Housing	1	EN1.4408	EN 1.0619
21	Housing Bolt	4	A2/Stainless Steel 304	Alloy Steel
22	Travel Stop Plate	1	A2/Stainless Steel 304	Zinc Plated Carbon Steel
23	Travel Stop Sleeve	1	EN 1.4031/SS304	EN 1.4031/SS304
24	Travel Stop Bolt	1	A2/Stainless Steel 304	A2/Stainless Steel 304
25	Handle	1	Stainless Steel 304 or Ductile Iron****	Stainless Steel 304 or Ductile Iron****
26	Lock Nut	2	A2/Stainless Steel 304	A2/Stainless Steel 304
27	Handle Bolt	1	Carbon Steel	Carbon Steel
28	Handle Sleeve	1	Vinyl through DN50	Vinyl through DN50
29	Locking Device	1	A2/Stainless Steel 304	A2/Stainless Steel 304
30	Snap Ring	2	Stainless Steel 304	Dacromet Plated Carbon Steel

* EN 1.4542 available as an alternative

** Quantity depends on valve size.

*** RPTFE packing is composed of 3 or 4 pieces dependant on size. Graphite packing is composed of a single piece.

**** Ductile iron used for valve sizes \geq DN65.

Flow-Tek offers the seat, body seal, thrust washer and stem packing as recommended spare parts.

These parts are available as a packaged repair kit.

Note:

Additional materials available upon request.

Contact Bray for additional information.

DN15 - DN50



DN65 - DN300

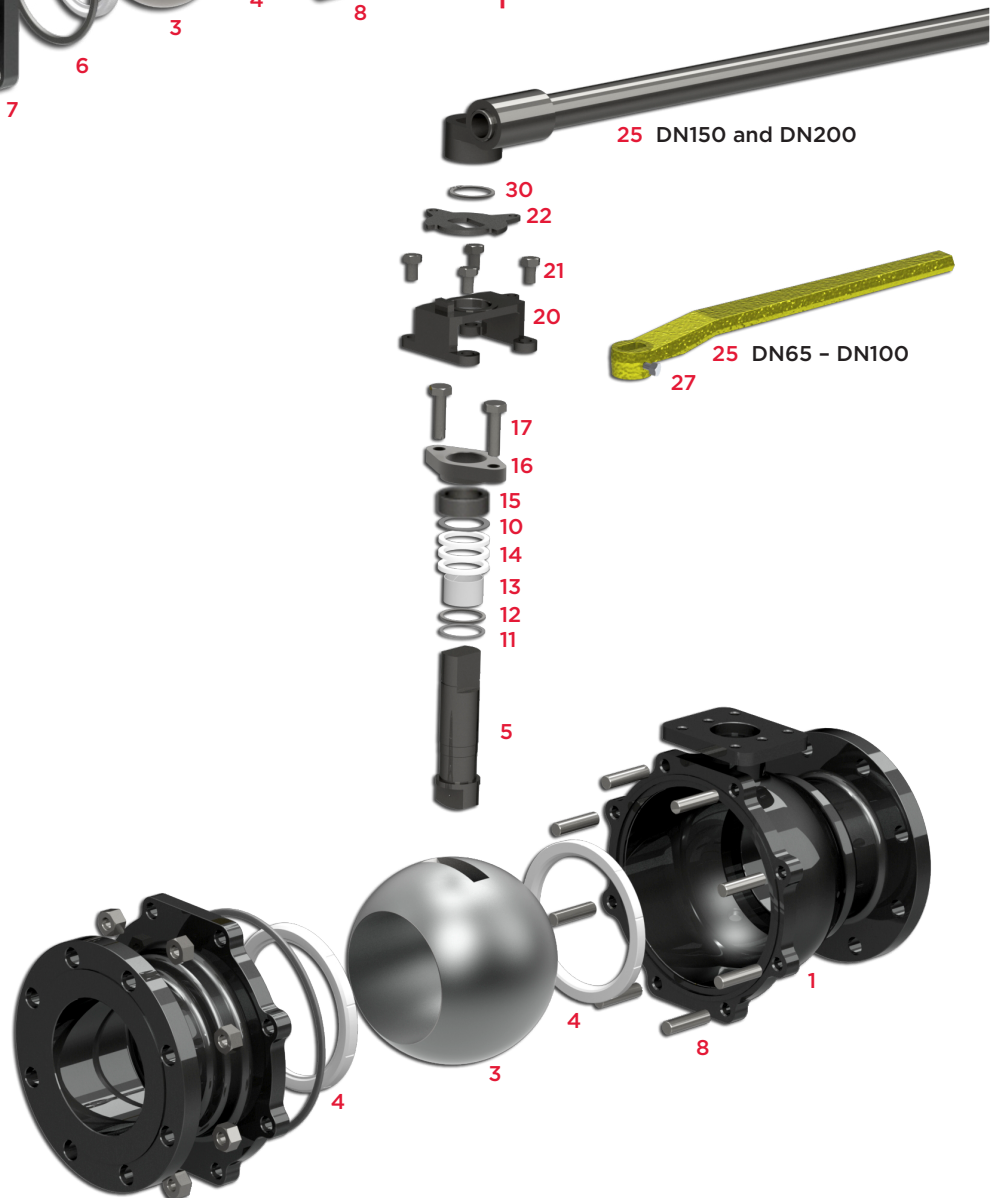

DIMENSIONS | DN15 - DN50

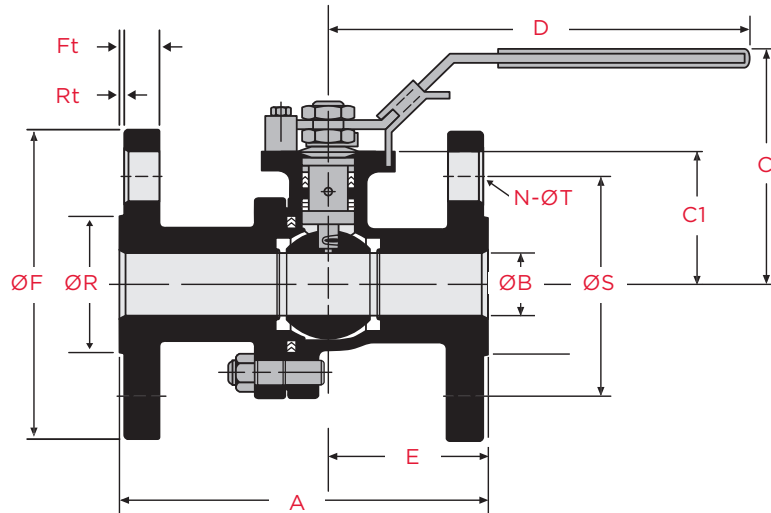

DIMENSIONS [mm]

DN	PN	A*			ØB	C	C1	D	E	ØF	Ft	ØR	Rt	ØS	N x ØT
		F1	F4	F5											
15	10-40	130	115	-	15	66	40	165	50.5	95	16	45	2	65	4 x 14
20	10-40	150	120	-	20	74	42.5	165	53.0	105	18	58	2	75	4 x 14
25	10-40	160	125	-	25	87	52	200	53.0	115	18	68	2	85	4 x 14
32	10-40	180	130	-	32	91	56	200	57.0	140	18	78	2	100	4 x 18
40	10-40	200	140	-	38	107	66	250	57.5	150	18	88	3	110	4 x 18
50	10-40	230	150	-	50	115	75	265	63.0	165	20	102	3	125	4 x 18

NAMUR Stem Slot included on DN65 - DN100 valves for ease of limit switch mounting.

*Face to Face dimensions in accordance with:

- > DIN 3202 F1 | EN-558 Series 1
- > DIN 3202 F4 | EN-558 Series 14 + 27
- > DIN 3203 F5 | EN-558 Series 15

(Refer to Table 2 in BS EN-558:2008+A1:2011 for additional information)

**Torque at maximum rated pressure, clean water, TFM 1600 seating material. Other seat materials exhibit different torques.

Please refer to TB 1005 for specific torques.

DIMENSIONS | DN65 - DN300

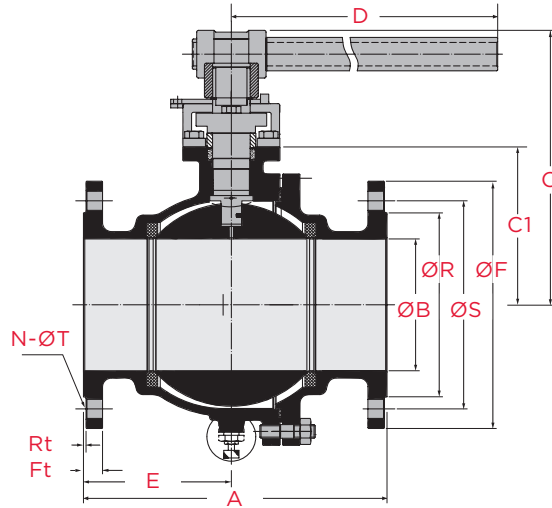

DIMENSIONS [mm]

DN	PN	A*			ØB	C	C1	D	E			Ft	ØR	Rt	ØS	N x ØT
		F1	F4	F5					F1, F4	F5	ØF					
65	10-16		170	-				78.3	-	185	18	122	3	145	4 x 18	
	25-40	290	-	-	65	158	86	390	133.3	-	185	22	122	3	145	8 x 18
80	10-16		180	-				82.0	-	200	20	138	3	160	8 x 18	
	25-40	310	-	-	76	166	93	390	151.5	-	200	24	138	3	160	8 x 18
100	10-16		190	-				87.5	-	220	20	158	3	180	8 x 18	
	25-40	350	-	-	101.5	183	112	390	176.5	-	235	24	162	3	190	8 x 22
125	10-16		-	325				178.0	154.5	250	22	188	3	210	8 x 18	
	25-40	400	-	-	127	272.5	164.2	990	188.0	154.5	270	26	188	3	220	8 x 26
150	10-16		-	350				193.5	170.5	285	22	212	3	240	8 x 22	
	25-40	480	-	-	152	285	182	990	193.5	170.5	300	28	218	3	250	8 x 26
200	10	600	-	400				212.0	200.0	340	24	268	3	295	8 x 22	
	16	600	-	400				212.0	200.0	340	24	268	3	295	12 x 22	
	25	-	-	-	200	323	193	990	234.0	-	360	30	278	3	310	12 x 26
	40	-	-	-				234.0	-	375	34	285	3	320	12 x 30	
250	10	-	-	-				266.0	-	395	26	320	3	350	12 x 22	
	16	-	-	450				266.0	225.0	405	26	320	3	355	12 x 26	
	25	-	-	-	250	348	250	990	284.0	-	425	32	335	3	370	12 x 30
	40	-	-	-				284.0	-	450	38	345	3	385	12 x 33	
300	10	-	-	-				305.0	-	445	26	370	4	400	12 x 22	
	16	-	-	500				305.0	500.0	460	28	378	4	410	12 x 26	
	25	-	-	-	300	388	291	990	325.0	-	485	34	395	4	430	16 x 30
	40	-	-	-				325.0	-	515	42	410	4	450	16 x 33	

TOP FLANGE | DN15 - DN50

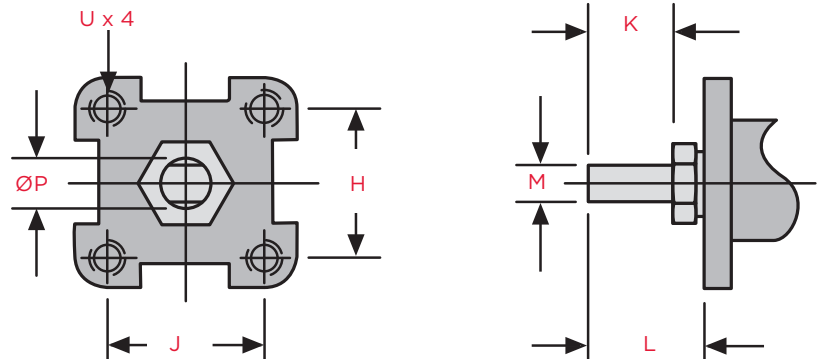

DIMENSIONS [mm]

DN	PN	H	J	ISO	Ø BC	U	K	L	M	ØP
15	10 - 40	-	-	F04	42.0	M5x0.8	7.5	14.0	6.35	M10x1.0
20	10 - 40	-	-	F04	42.0	M5x0.8	7.5	14.0	6.35	M10x1.0
25	10 - 40	-	-	F05	50.0	M6x1.0	11.0	19.0	8.0	M12x1.25
32	10 - 40	-	-	F05	50.0	M6x1.0	11.0	19.0	8.0	M12x1.25
40	10 - 40	-	-	F07	70.0	M8x1.25	14.0	23.0	9.5	M16x1.5
50	10 - 40	-	-	F07	70.0	M8x1.25	14.0	23.0	9.5	M16x1.5

TOP FLANGE | DN65 - DN300

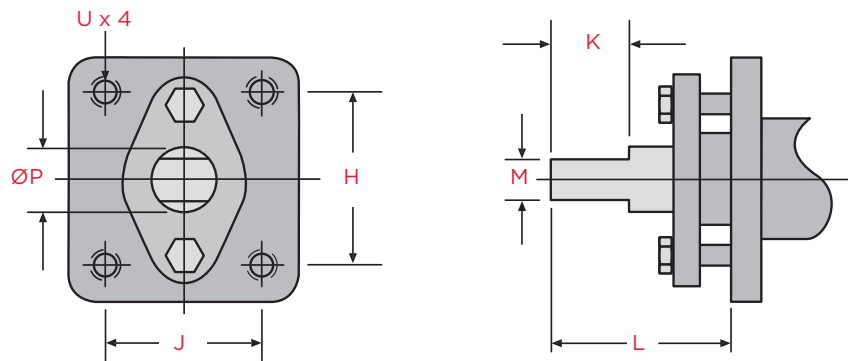

DIMENSIONS [mm]

DN	PN	H	J	Ø BC	U	K	L	M	ØP
65	10 - 40	90.0	47.6	-	M12	44.5	78.0	17.0	28.0
80	10 - 40	90.0	47.6	-	M12	44.5	78.0	17.0	28.0
100	10 - 40	90.0	47.6	-	M12	44.5	78.0	17.0	28.0
125	10 - 40	85.7	85.7	121.2	M12	42.0	87.0	25.9	42.0
150	10 - 40	85.7	85.7	121.2	M12	42.0	87.0	25.9	42.0
200	10 - 16	85.7	85.7	121.2	M12	42.0	98.0	25.9	42.0
	25 - 40								
250	10 - 16	115.0	115.0	162.6	M16	54.5	95.0	35.0	50.0
	25 - 40								55.0
300	10 - 16	115.0	115.0	162.6	M16	54.5	95.0	35.0	50.0
	25 - 40								55.0

ADDITIONAL TECHNICAL DATA

TORQUE | FLOW RATE | WEIGHT

SIZE	PRESSURE RATING	FLOWRATE	TORQUE*	WEIGHT [kg]		
				F1	F4	F5
DN	PN	Kv	Nm			
15	10 - 40	28	5	2.5	2.5	-
20	10 - 40	52	8	4.0	4.0	-
25	10 - 40	91	12	5.5	5.0	-
32	10 - 40	171	20	8.0	7.5	-
40	10 - 40	238	31	9.0	8.5	-
50	10 - 40	433	50	12.0	10.5	-
65	10 - 16	675	56	16.5	14.5	-
	25 - 40	675	68	18.5	-	-
80	10 - 16	995	73	21.5	17.5	-
	25 - 40	995	96	25.0	-	-
100	10 - 16	1817	170	31.5	24.0	-
	25 - 40	1817	294	36.0	-	-
125	10 - 16	2585	300	57.0	-	53.5
	25 - 40	2585	486	68.0	-	-
150	10 - 16	4325	367	79.5	-	76.5
	25 - 40	4325	599	-	-	-
200	10	8304	492	146	-	142
	16	8304	492	146	-	-
	25	8304	717	-	-	-
	40	8304	717	-	-	-
250	10	12975	1487	-	-	-
	16	12975	1487	-	-	228
	25	12975	1804	-	-	-
	40	12975	1804	-	-	-
300	10	18165	2139	-	-	-
	16	18165	2139	-	-	314
	25	18165	2506	-	-	-
	40	18165	2506	-	-	-

* Torque at maximum rated pressure, clean water, TFM 1600 seating material. Other seat materials exhibit different torques. Please refer to TB 1005 for specific torques.

All values subject to change without notice.

All weights are approximate values as these depend on material selection.

SINCE 1986, BRAY HAS PROVIDED FLOW CONTROL SOLUTIONS FOR A VARIETY OF INDUSTRIES AROUND THE WORLD.

VISIT **BRAY.COM** TO LEARN MORE ABOUT BRAY PRODUCTS AND LOCATIONS NEAR YOU.

HEADQUARTERS

Bray International, Inc.

13333 Westland East Blvd.

Houston, Texas 77041

Tel: +1.281.894.5454

All statements, technical information, and recommendations in this bulletin are for general use only. Consult Bray representatives or factory for the specific requirements and material selection for your intended application. The right to change or modify product design or product without prior notice is reserved. Patents issued and applied for worldwide. Bray® is a registered trademark of Bray International, Inc.

© 2025 BRAY INTERNATIONAL. ALL RIGHTS RESERVED. BRAY.COM

B-FT-2807_F15-EN_EU-EN_2026-05-18



THE HIGH PERFORMANCE COMPANY

BRAY.COM