McCANNALOK SERIES 41R SUGAR INDUSTRY

- > Large Cv
- > Lighter Weight
- > Easy Automation
- > Award-winning Design
- > Steam Valves for Evaporators
- > 100% Bidirectional Bubbletight
- > Evaporator Steam and Escape Valves



 **Bray**[®]

WWW.BRAY.COM

THE HIGH PERFORMANCE COMPANY

SERIES 41R EVAPORATOR STEAM VALVE ZERO LEAKAGE BUTTERFLY VALVES

- > 100 PSI rated
- > Double flanged design
- > -20°F to 500°F (-29°C to 260°C)
- > Zero-leakage, bidirectional shut-off to full rated pressure



Bray is proud to offer the Bray/McCannalok line of specially designed high performance butterfly valves for the Sugar Industry. These valves are structured to handle the low pressure steam of evaporators. This is also the same valve that for 30 years has proven to be the leader in double offset design for the process industry.

This valve incorporates the same proven design features of the standard Bray/McCannalok valve but in a lighter, more economical configuration specifically designed for the sugar industry steam services. It can be used along with the standard higher pressure Bray/McCannalok butterfly valves and shares the same spare parts, thereby reducing the need for special or different inventory.

The Bray/McCannalok's unique, patented design received Chemical Processing's Vaaler Award for Best Product shortly after it was introduced. The simple, innovative design offers rugged reliability and extremely easy maintenance in the field. Independent and internal tests have proven Bray/McCannalok's superior service life capability, with zero-leakage shut-off through over 100,000 cycles. The Bray/McCannalok valves can be easily automated with manual, pneumatic or electric actuators.

After a test of over 100,000 cycles at 720 psi, the seat remained in excellent condition, continuing to provide a bidirectional zero-leakage seal. Even after more than 878,000 cycles at 2 psi, the Bray/McCannalok High Performance Valve still sealed zero-leakage in both directions.

For over 30 years the reliability of the Bray/McCannalok has been conclusively proven, both in lab tests and thousands of field applications.

DOUBLE OFFSET STEM AND DISC DESIGN

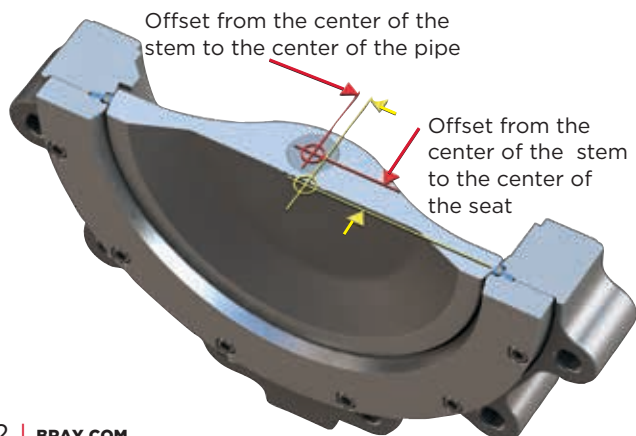

SEAT DESIGN

The unique, two-part seat assembly consists of a resilient energizer which is totally encapsulated by the seat. The assembly is locked in the body recess by a full-faced seat retainer. This simple, reliable and proven combination results in many exclusive advantages including:

- > The energizer is completely isolated from all contact with the line media by the seat.
- > Serrations in the seat retainer and body recess secure the seat assembly in place regardless of disc position.
- > The full-faced retainer is bolted to the body, locking the seat in the correct position. The seat is secured even without the mating flange.
- > The closely confined and well supported seat is energized by the disc and line pressure. The higher the pressure, the tighter the seal. In low pressure and vacuum applications, the energized seat offers superior sealing and longer service life than many other designs.
- > Line media is sealed to zero-leakage in both directions.
- > The seat is self-adjusting for wear and temperature changes.
- > Seat replacement is extremely easy. Just remove the seat retainer, rotate the disc into the closed position and place a new seat assembly in the machined recess of the body. This simple procedure will not disturb the disc or stem.

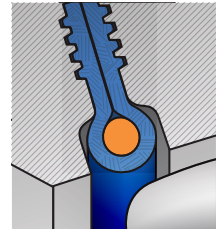

Seat non-compressed as disc approaches.

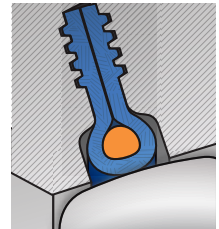

Disc in closed position; with no line pressure.

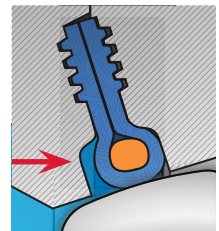

Disc in closed position; line pressure applied from the left.

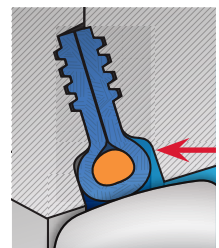

Disc in closed position; line pressure applied from the right.

No.	Name	Material
1	Body	Phosphatized Ductile Iron Phosphatized Carbon Steel
2	Disc	Carbon Steel with Stainless Steel Edge
3	Stem	17-4 PH Stainless Steel
4	Heavy Duty Coiled Pin	420 Stainless Steel
5	Seat	RPTFE ¹
6	Seat Retainer	Phosphatized Carbon Steel
7	Retainer Screws	Carbon Steel
8	Locating Plug	Phosphatized Carbon Steel
9	Capscrews	Carbon Steel
10	Bearing	316 Stainless Steel with TFE
11	Stem Seal Kit	PTFE
12	Disc Spring	18-8 Stainless Steel
13	O-Ring	PTFE
14	Gland Ring	316 Stainless Steel
15	Split Ring	18-8 Stainless Steel
16	Gland Retainer	Phosphatized Carbon Steel
17	Stud	316 Stainless Steel
18	Nut	18-8 Stainless Steel
19	Lock Washer	18-8 Stainless Steel
20	Grounding Washer	18-8 Stainless Steel
21	Disk Spacers	316 Stainless Steel
22	Key	18-8 Stainless Steel
23	Capscrews	Carbon Steel
24	Mounting Plate	Phosphatized Carbon Steel
25	Retaining Ring	18-8 Stainless Steel

¹RTFE is supplied by Bray as RPTFE (reinforced polytetrafluoroethylene).

Blow-Out Proof Stem

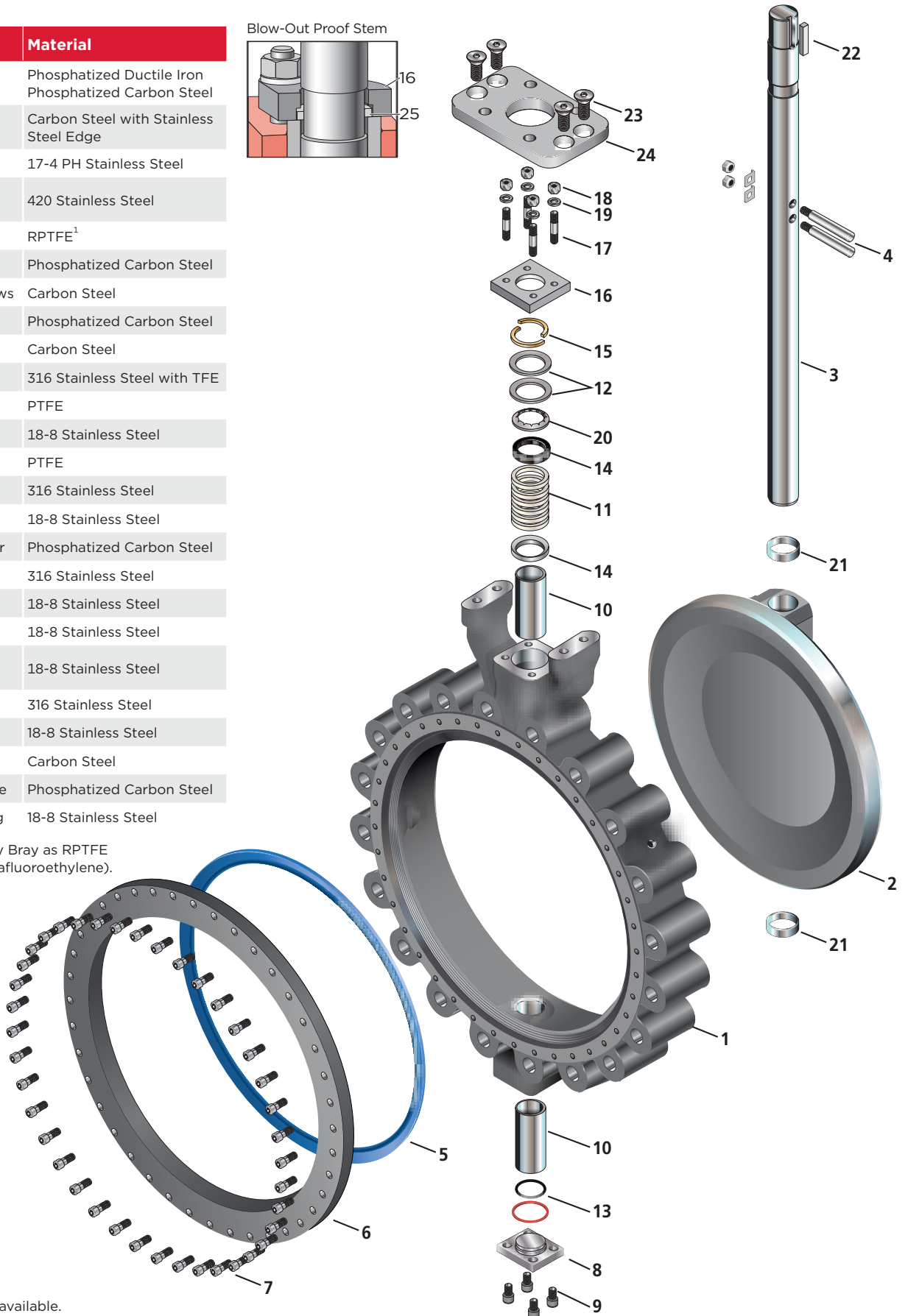
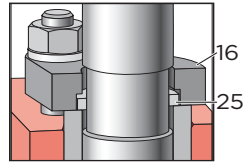

Other materials are available.
Please consult a Bray representative for your specific application.

SINCE 1986, BRAY HAS PROVIDED FLOW CONTROL SOLUTIONS FOR A VARIETY OF INDUSTRIES AROUND THE WORLD.

VISIT **BRAY.COM** TO LEARN MORE ABOUT BRAY PRODUCTS AND LOCATIONS NEAR YOU.

HEADQUARTERS

Bray International, Inc.

13333 Westland East Blvd.

Houston, Texas 77041

Tel: +1.281.894.5454

All statements, technical information, and recommendations in this bulletin are for general use only. Consult Bray representatives or factory for the specific requirements and material selection for your intended application. The right to change or modify product design or product without prior notice is reserved. Patents issued and applied for worldwide. Bray® is a registered trademark of Bray International, Inc.

© 2022 BRAY INTERNATIONAL, INC. ALL RIGHTS RESERVED. BRAY.COM

EN_BR_BRO_1052_S41RSugarIndustry_20220321



THE HIGH PERFORMANCE COMPANY

BRAY.COM