SOLUTIONS & CAPABILITIES

VALVE AUTOMATION CENTERS



 **Bray**[®]

BRAY.COM

THE HIGH PERFORMANCE COMPANY

Innovation Meets Excellence

VALVES

ACTUATORS

CONTROLS

INTEGRATION

INTELLIGENCE

Turnkey flow solutions with 100% integration, calibration, and testing of Bray or qualified third party products — backed by comprehensive calculations, documentation, and traceability.

CAPABILITIES INCLUDE:

NON-DESTRUCTIVE
EXAMINATION

LEAKAGE TESTING
(HYDRO, AIR, GAS)

PERFORMANCE TESTING

FACTORY ACCEPTANCE TESTING
(FAT) WITH PHOTOS & VIDEO

PARTIAL STROKE &
FULL STROKE TESTING

CALIBRATION

ADVANCED DIAGNOSTICS

CONTROL VALVE
OPTIMIZATION

NETWORK COMMUNICATION
CONFIGURATION

SIL CALCULATIONS

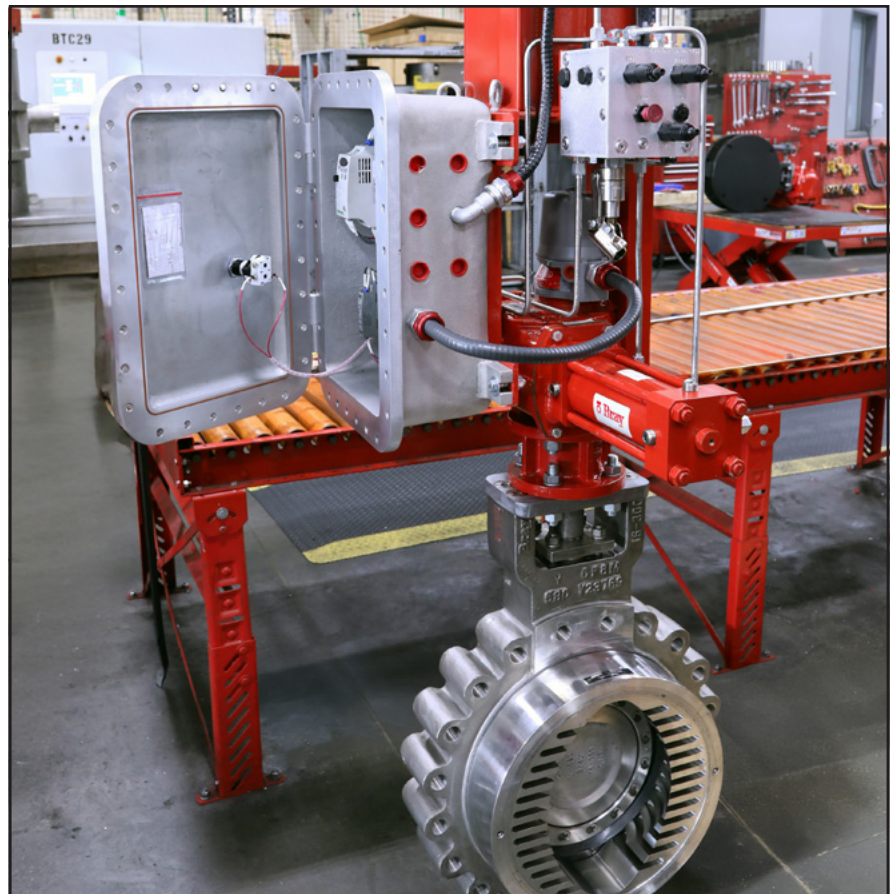

*Engineered solutions to fit
your unique applications.*

Speed & Agility

- > Streamlined specifications process with fast, accurate quoting to accelerate project timelines.
- > Quick turnaround assembly, testing, and delivery of automated packages.
- > Instant access to technical expertise and support — ensuring seamless project execution from start to finish.

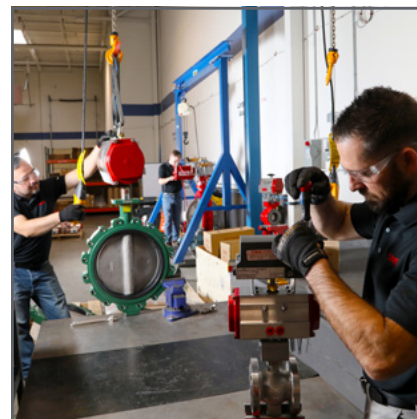

Complete assembly and thorough testing of automated packages.

Customization

- > Engineered solutions tailored for your unique application challenges.
- > Fully integrated and tested packages using high performance Bray products or fully qualified complementary products.
- > Automation application engineers on staff to provide immediate technical expertise and customer support.

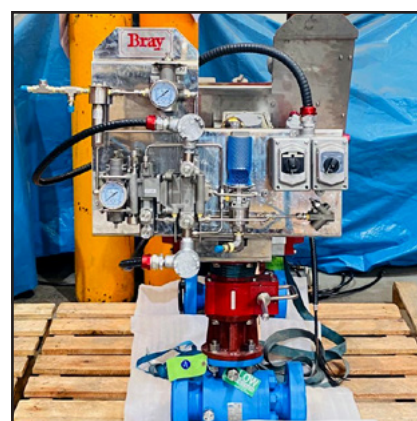

Integrated solutions to solve complex challenges..

Scalability

- > State of the art technology, tools, and equipment, with a comprehensive range of valve automation products.
- > Product and application expertise, ranging from sizing recommendations to full training and support services.
- > Complete global capabilities and services, including sourcing options to meet unique regional requirements.



Scalability to meet project demands.

Application Specific Designs

1 CRUDE OIL METERING

Control valve | 30 degree segment | Explosion proof positioner | NACE compliant | Tested to API 6D

2 NUCLEAR POWER GENERATION

Isolation valve | Rack & pinion actuator | Pneumatic backup tank | Seismic testing performed

MINING

Slurry valve | Purge ports | Scotch yoke actuator

WATER TREATMENT

Isolation valve | Scotch yoke actuator | Speed controls

3 HYDROCARBON & CHEMICAL TANK STORAGE

Jetty manifold control and isolation valves | Pneumatic actuators with positioners & proximity sensors

4 GAS METERING STATION

Safety shutdown valves | Zero emission actuators | Accumulators | Hydraulic power unit cabinets | EPA friendly

5 ROCKET LAUNCH SYSTEM

Nitrogen charged water deluge system | Fast acting | Scotch yoke actuator | Specific speed operation

6 TURBO EXPANDER

Cryogenic isolation valve | Turbine trip | Scotch yoke actuator | Fast acting (0.5 second close) | Redundant solenoids | SIL 2 capable

7 DRINKING WATER PUMP STATION

Control valve | Third party electric actuation | Local control station

8 CHEMICAL POLYMER REFINING

Venting valve | Scotch yoke actuator with positioner | Fast acting | Declutchable gear override

9 SUGAR & ETHANOL PLANT

Filtration | Inlet circuit isolation valves | High cycle | Pneumatic actuation with proximity sensor

10 PULP & PAPER PLANT

Junk trap cyclone | Abrasive media | High cycle knife gate valves | Pneumatic piston cylinders (on/off)

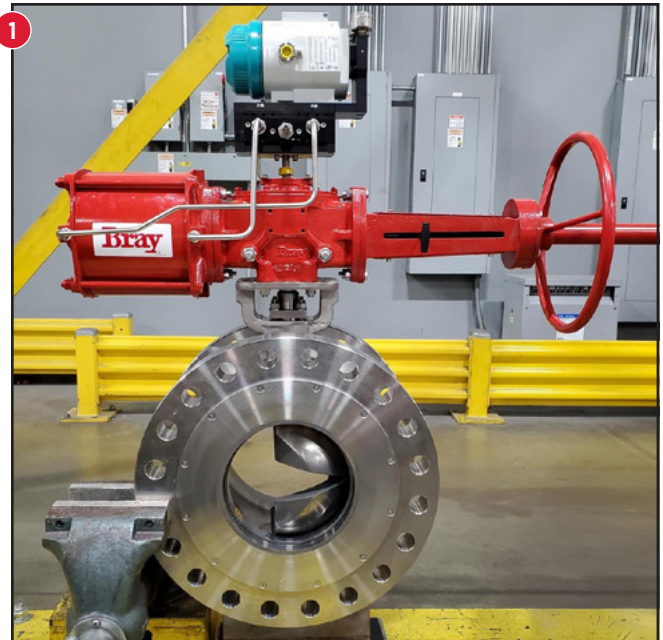

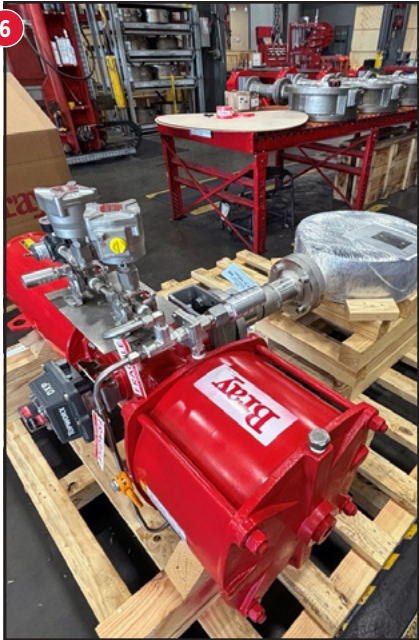

Powering Your Success

SERVICE

SUPPORT

TRAINING

DOCUMENTATION

WARRANTIES

Every solution meets the highest standards of performance, quality, and reliability — backed by warranted processes and unmatched expertise.

CERTIFICATIONS INCLUDE:



Every product undergoes thorough quality checks.

Partnership

- > Product and application expertise, ranging from sizing recommendations to training and support services.
- > Engineered solutions delivered with a full suite of available support, including startup commissioning and field service.
- > Single point of contact to simplify communication and decisions — saving time and money.

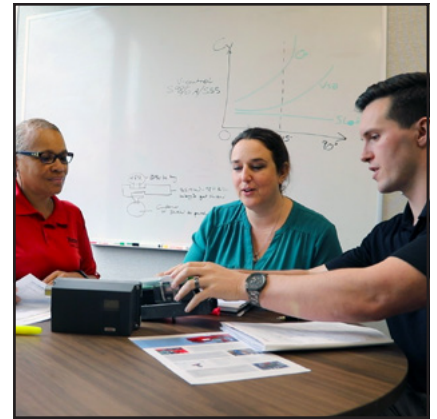

Full support throughout all project phases.

Trusted Solutions

- > Our Quality Management System, per ISO 9001, ensures every product is delivered with industry leading quality.
- > Stringent processes are followed with all required commercial and technical documentation provided.
- > Bray takes full ownership of the product lifecycle, with complete support — from initial purchase to ongoing maintenance.
- > Bray products are backed by a commitment to long-term performance and customer satisfaction.

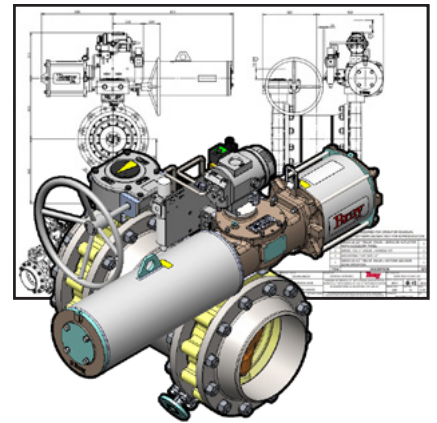

3D modeling and drawings provided.

Global Reach Local Presence

- > Complete global capabilities and services, including sourcing options to meet unique regional requirements.
- > Wherever you are...experience the Bray difference. Contact us to learn more about how we can support your valve automation needs globally.



Delivery to support your needs... wherever you are.

SOLUTIONS & CAPABILITIES

VALVE AUTOMATION CENTERS



SINCE 1986, BRAY HAS PROVIDED FLOW CONTROL SOLUTIONS FOR A VARIETY OF INDUSTRIES AROUND THE WORLD.

VISIT **BRAY.COM** TO LEARN MORE ABOUT BRAY PRODUCTS AND LOCATIONS NEAR YOU.

HEADQUARTERS

Bray International, Inc.

13333 Westland East Blvd.

Houston, Texas 77041

Tel: +1.281.894.5454

GLOBAL COMPANY | REGIONAL FOCUS | LOCAL PRESENCE



All statements, technical information, and recommendations in this bulletin are for general use only. Consult Bray representatives or factory for the specific requirements and material selection for your intended application. The right to change or modify product design or product without prior notice is reserved. Patents issued and applied for worldwide. Bray® is a registered trademark of Bray International, Inc.

© 2025 BRAY INTERNATIONAL. ALL RIGHTS RESERVED. BRAY.COM

EN_OVW_VAC_Global_20250417_01



THE HIGH PERFORMANCE COMPANY

BRAY.COM