

**VAL-NR180 Series  
 Electric Actuators  
 Non-Spring Return**

**FEATURES & BENEFITS**

180 lb Force Output in a Compact Unit	<ul style="list-style-type: none"> <li>Covers a wide range of applications with one actuator</li> </ul>
Magnetic Clutch	<ul style="list-style-type: none"> <li>Provides constant output force for positive closeoff of valves, and protects motor in stall conditions</li> </ul>
Durable Construction	<ul style="list-style-type: none"> <li>Provides a longer cycle life</li> </ul>
Unique Yoke Design	<ul style="list-style-type: none"> <li>Easy field mounting to valve reduces installation and stroke adjustment time</li> </ul>
Selectable Direct/Reverse Action	<ul style="list-style-type: none"> <li>Eases setup and installation</li> </ul>
Built-In Resistor for Current Input Control	<ul style="list-style-type: none"> <li>Provides greater application flexibility</li> </ul>



The VAL-NR180 Series synchronous motor-driven actuator provides incremental (three wire), incremental with feedback or proportional control of valves with up to 3/4 in. stroke in heating, ventilating, and air conditioning applications.

This compact, non-spring return actuator has a 180 lb force minimum and responds to a variety of input signals.

The VAL-NR180 Series can be easily field mounted or ordered factory coupled to Bray 2-way and 3-way globe valves.

## VAL-NR180 Series

### Electric Actuators

#### Non-Spring Return

## OPERATION

The VAL-NR180 Series actuators use a reversible synchronous motor and a magnetic clutch to accurately position the valve. This combination can reliably generate 180 lb of force in either direction.

The actuator maintains the shutoff force even if power to the actuator is removed. When the controller provides a signal for the actuator to move in the opposite direction, the shutoff force is reduced and the valve modulates.

The magnetic clutch maintains a constant load at the end of travel, which ensures tight valve shutoff and compensates for seat wear.

### Incremental Control—VAL-NR180-521

A controller provides 24 VAC to the Up or Down, and Common terminals depending upon the desired movement of the valve stem. This signal causes the motor to rotate in the desired direction. The gear train and drive screw move the valve stem up or down. When the controller stops sending a signal, the valve stem is held in place and remains in position, until the next control signal is sent.

**Note:** In incremental applications, there is no direct correlation between valve position and controller output (0 to 100%). If correlation is important, use proportional control or actuators that provide position feedback.

### Feedback Control—VAL-NR180-522

VAL-NR180-522 actuator operation is the same as the -521, while providing position feedback. A 2k ohm position feedback potentiometer provides remote position indication to a controller.

The 0 to 2k ohm feedback potentiometer is proportional to the full 3/4 in. actuator stroke and includes a field adjustable zero.

### Proportional Control—VAL-NR180-541

The VAL-NR180-541 provides a proportional stroke in relation to the input control signal of 0 to 10 VDC (maximum), with an adjustable starting point of 0 to 8 VDC and an adjustable span of 2 to 10 VDC. Current input may be jumper selected for 0 to 20 mA (maximum) with an adjustable starting point of 0 to 16 mA and an adjustable span of 4 to 20 mA. It also features stroke selection and Direct Acting (DA) or Reverse Acting (RA) jumpers.

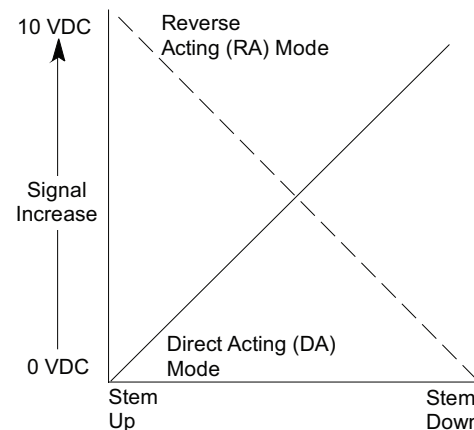

An electronic controller provides the proportional input signal to the actuator. This signal is compared to the actual valve position via the internal feedback potentiometer.

The internal circuit activates the motor to rotate in the proper direction. The gear train and drive screw move the valve stem to the position called for by the input signal.

**Note:** The actuator will accept control signals of 20 VDC maximum with signals over 10 VDC ignored by the actuator.

**VAL-NR180 Series  
 Electric Actuators  
 Non-Spring Return**

**DIMENSIONS**

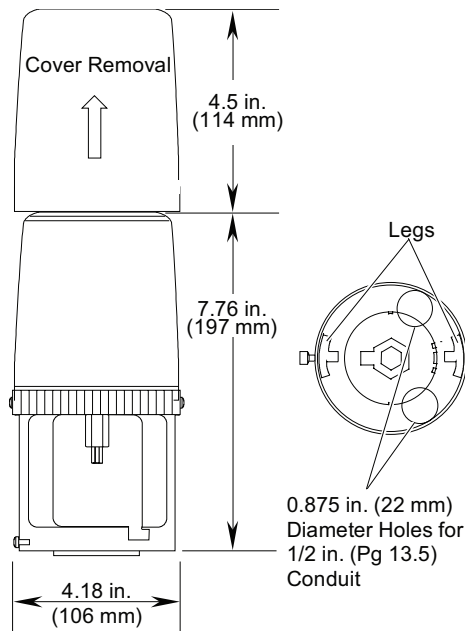

**WIRING**

**WARNING:** Equipment Damage Hazard. Disconnect the power supply before wiring connections are made to prevent possible damage to the equipment. Make and check all wiring connections before applying power to the system. Short-circuited or improperly connected wires may result in permanent damage to the unit.

All wiring must be in accordance with applicable electrical code requirements. Input lines to the actuator must be wired correctly for the valve to move in the proper direction.

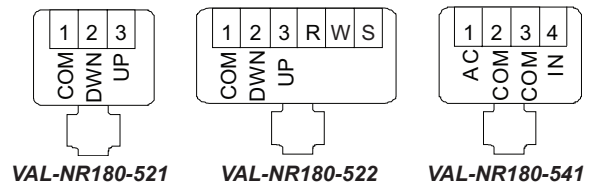

**MODEL INFORMATION**

Code Number	Description
VAL-NR180-521	Three Wire Incremental
VAL-NR180-522	Three Wire Incremental with Position Feedback
VAL-NR180-541	Proportional, 0 to 10 VDC

**Note:** Follow wiring and termination instructions detailed in the applicable controller manual.

**VAL-NR180 Series**  
**Electric Actuators**  
**Non-Spring Return**

**SPECIFICATIONS**

Power Requirements	24 VAC (20 to 30 VAC), 50/60 Hz
	VAL-NR180-521: 6.7 VA Nominal
	VAL-NR180-522: 6.7 VA Nominal
	VAL-NR180-541: 8.7 VA Nominal
Input Signal	Incremental: 24 VAC, 50/60 Hz
	Proportional: 0 to 10 VDC or 0 to 20 mA (jumper selectable)
Input Signal Adjustments (Proportional)	Input Signal: VDC or mA (jumper selectable)
	Offset: 0 to 8 VDC/0 to 16 mA
	Span: 2 to 10 VDC/4 to 20 mA
	Action: Drive up (DA) or drive down (RA) on signal increase (jumper selectable)
	Factory Setting: Calibrated 1 to 9 ± 0.5 VDC for 0 to 10 VDC controller operation, Direct Acting (DA), 3/4 in. (19 mm) stroke
Input Impedance (Proportional)	Voltage: 100k Ω
	Current: 500 Ω
Feedback Signal	VAL-NR180-522: 0 to 2k Ω ±20% for 25/32 in. (20 mm) stroke, 1/4 watt
Mechanical Output	180 lb force (800 N) minimum
Stroke Range	25/32 in. (20 mm) maximum
Nominal Stroke Timing	26 seconds for 5/32 in. (8 mm) stroke
	60 Hz: 42 seconds for 1/2 in. (13 mm) stroke
	62 seconds for 3/4 in. (19 mm) stroke
	50 Hz: 32 Seconds for 5/32 in. (8 mm) stroke
	50 seconds for 1/2 in. (13 mm) stroke
	74 seconds for 3/4 in. (19 mm) stroke
Electrical Connections	Screw
	VAL-NR180-521: 24 to 14 AWG
	Terminals
VAL-NR180-522: 24 to 16 AWG	
VAL-NR180-541: 24 to 16 AWG	
Mechanical Connections	1/4-28 UNF-2B thread for valve stem connection
Enclosure	NEMA 2, IP42
Ambient Operating Conditions	23 to 131°F (-5 to 55°C), 10 to 90% RH, non-condensing, 86°F (30°C) maximum dew point
Ambient Storage Conditions	-4 to 150°F (-20 to 65°C), 5 to 95% RH, 86°F (30°C) maximum dew point
Dimensions	4.18 in. diameter x 7.76 in. high (106.3 x 197.2 mm)
Shipping Weight	2.2 lb (1.0 kg)
Agency Compliance	UL 873 Listed, File E27734, Guide XAPX, Class 2 operation, plenum rated
	CSA C22.2 No. 139 Certified, File LR85083, Class 3221 01, Class 2 operation
	CE Directive 89/336/EEC

The performance specifications are nominal and conform to acceptable industry standards. For application at conditions beyond these specifications, consult the local BRAY office. BRAY shall not be liable for damages resulting from misapplication or misuse of its products.

All statements, technical information, and recommendations in this bulletin are for general use only. Consult Bray representatives or factory for the specific requirements and material selection for your intended application. The right to change or modify product design or product without prior notice is reserved.

 **Bray** CONTROLS  
Commercial Division

A Division of BRAY INTERNATIONAL, Inc.  
13333 Westland East Blvd. Houston, Texas 77041  
Toll Free: 888.412.BRAY(2729), FAX 281.894.9499 www.bray.com  
© 2003 Bray International. All rights reserved. NR180070306  
Bray® is a registered trademark of Bray International, Inc.