



**Bray**®

**Products for the Water Industry**

**Water & Wastewater Treatment**  
Filtration • Purification • Desalination

**NSF / ANSI 61 CERTIFIED**



# Bray Out Performs AWWA Verification Criteria

## Bray Resilient Seated Butterfly Valves

are designed, manufactured and tested to meet or exceed AWWA C504, Section 5.0 performance criteria. Also, Bray valves have exceeded a million cycles in actual AWWA type services, far in excess of the AWWA C504, Section 5.1.4.3 cycling performance standard. Pressure testing to ensure shell, seat and stem seal's integrity is performed on every valve manufactured by Bray Controls.

Bray Controls has been successfully providing resilient seated valves for over 20 years for many applications in Water, Wastewater, Filtration and Desalination applications. Bray peroxide cured EPDM seats exhibit outstanding performance in water services. Third party testing of Bray EPDM per ASTM D6284 shows excellent compatibility with chlorine/chloramine additives.

## Automation – Single Source Responsibility

As a manufacturer of electric and pneumatic actuators and accessories, Bray takes full responsibility for the operation of the valve/actuator package. All Bray actuators direct-mount to the valves without the need for costly brackets, linkages and couplers. With this breadth of product and experience, Bray Controls is the fastest growing automated valve producer in the water and wastewater industry.



As the leading supplier of automated butterfly valves to the water filter and air blower OEMs, Bray products are standard at many water, wastewater treatment and desalination plants. Using state-of-the-art materials and design, Bray butterfly valves and actuators have been successfully applied in the following applications:

- Raw water
- Fresh water
- Wastewater
- Digester Gas
- Aeration
- Chemical Treatment
- Reverse Osmosis Filtration
- Backwash Filters
- Seawater Intake
- Power

*Bray resilient seated butterfly valves are approved and certified worldwide for potable water applications*



<b>Service Conditions</b>	<b>AWWA C504 Specification</b>	<b>BRAY Resilient seated Valves</b>
<b>Media</b>	Fresh Water	Fresh Water, Wastewater, Seawater & Chemicals
<b>PH Limits</b>	6 to 12	3 to 13
<b>Temperature Limits</b>	125°F (52°C) Maximum	250°F (121°C) Maximum
<b>Velocity Limits-Liquid</b>	16 ft/sec. (4.9 m/sec.)	30 ft/sec. (9.1 m/sec.)
<b>Cycle Test Requirements</b> <i>Valve Size - In. (mm)</i>	<b>AWWA Minimum Cycles</b>	<b>BRAY Resilient seated Valve Cycles</b>
3" (75) - 72" (1800)	1,000 - 10,000	5 - 100 TIMES GREATER THAN AWWA
<b>Valve Components</b>	<b>AWWA C504 Specification</b>	<b>BRAY Resilient seated Valves</b>
<b>Valve body</b>	EXPOSED TO Media	ISOLATED FROM Media
<b>Valve disc</b>	EXPOSED TO Media (Ductile Iron with Stainless Steel Edge)	EXPOSED TO Media (NSF/FDA Approved Nylon 11 Coated Ductile Iron)
<b>Valve stem</b>	EXPOSED TO Media	ISOLATED FROM Media

# Resilient Seated Butterfly Valves Sizes 2" – 96" (50mm - 2400mm)

## INTERNAL DISC/STEM CONNECTIONS

Bray offers three disc-to-stem connections, Double 'D', Splined and Double Key. These internal non-wetted connections eliminate typically exposed external disc-to-stem connections such as screws or taper pins which can:

- Result in leak paths, erosion, corrosion and vibration failures.
- Require difficult machining for disassembly.
- Require replacement of disc and stem upon failure, since both are matched for the life of the valve.

Disassembly of Bray's internal connection is performed by simply pulling the stem out of the disc. Bray's precision machining of the disc and the stem connection minimizes hysteresis and produces maximum strength engagements. All stem designs incorporate a blow-out proof feature.

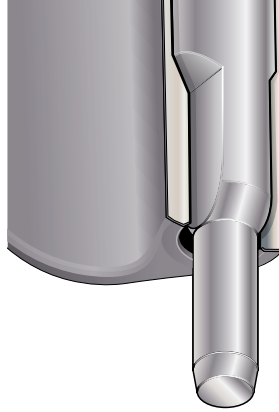

The **DOUBLE 'D'** disc-to-stem connection features matched precision machined flats on the stem and in the disc.  
Size 2" – 20" (50mm–500mm)

The **SPLINED** disc-to-stem connection features matched precision machined male splines in the stem and female in the disc.  
Size 22" – 48" (550mm–1200mm) .

The **DOUBLE KEYED** disc-to-stem connection features matched double keyways machined into the disc and stem. Keys engage the connection.  
Size 52" – 96" (1300mm–2400mm).



- **Body Styles:**  
Wafer, Lug  
Size 2" - 20" (50mm - 500mm)  
Double Flanged  
Size 3" - 96" (80mm - 2400mm)
- NSF /ANSI 61 Certified valves
- Body and stem are isolated from line media.
- FDA approved Nylon 11 coating on disc resists corrosion, abrasion and adherence of contaminants. Nylon 11 coating is also available on Bodies for salt air and corrosive environments.
- Smaller, lighter and a more cost effective solution compared to traditional AWWA butterfly valves
- Flow capacity is 30% higher on average than traditional AWWA butterfly valves
- EPDM seat compliant with FDA 21 CFR 177.2600

# High Performance Butterfly Valves

Sizes 2½" – 60" (65mm - 1500mm)

High Performance Butterfly Valves have been successfully applied to many applications in power plants, desalination plants and offshore oil/gas drilling and production platforms.

- **Wafer, Lug and Double Flanged Styles**
- **ANSI, DIN, BS and JIS flange patterns available**
- **ISO 5211 global standard**
- **Approvals/Compliance**
  - NSF/ANSI 61- Potable water
  - CE
  - ABS
  - DNV

Bray Controls is proud to offer the Bray/McCannalok line of high performance butterfly valves. This product line is recognized as a proven leader with over 35 years of successful service in process industries worldwide. The Bray/McCannalok's unique, patented design received Chemical Processing's Vaaler Award for Best Product shortly after it was introduced. The simple, innovative design offers rugged reliability and extremely easy maintenance in the field. Independent and internal tests have proven Bray/McCannalok's superior service life capability, with bubble-tight shut-off through hundreds of thousands of cycles.

The Bray/McCannalok valves can be automated with direct mount (no couplers) Bray pneumatic and electric actuators. When compared to gate, globe, ball,

diaphragm and plug valves, the Bray/McCannalok butterfly valve is significantly smaller and lighter weight, therefore installation space, time, and maintenance costs are greatly reduced.

The Bray/McCannalok High Performance Valve delivers the highest quality and highest value available for your requirements.

## DEAD-END SERVICE

Bray/McCannalok ANSI Class 150, 300 and 600 valves with lug bodies are rated for bidirectional dead-end service at the full differential pressure rating.

## TESTED:

Bray/McCannalok valves are tested to API 598 standards, including both low pressure and high pressure bi-directional leakage tests.

- **ANSI Class 150, 300 and 600 designs**
- **Carbon Steel, Stainless Steel, Duplex Stainless Steel or other Alloy Materials**
- **RTFE seats withstand temperatures up to 500 °F (260° C)**
- **Self-energized seat is pressure assisted, not pressure dependent**
- **Backwash filter valve with significant advantages versus plug valves (less weight, lower cost, excellent torque and control valve characteristics)**
- **Ideally suited to aeration and boiler room applications**



# Sanitary and PTFE Lined Butterfly Valves

Sizes 2" – 24" (50mm - 600mm)

## The Bray HPV PTFE High Performance Valve

- Wafer and Lug Styles
- PTFE, Conductive PTFE or UHMWPE Trim
- Rated for 150 psi (10.3 bar) differential pressure
- Excellent for the following applications:
  - Corrosive
  - High temperature
  - Abrasive
  - Digester gas

The Series 22/23 HPV line of butterfly valves sets the new standard of reliability and innovation. Extensive field research and engineering have developed this state-of-the-art design which provides excellent shut off protection (bubble-tight shut off) and high  $C_v$  values.

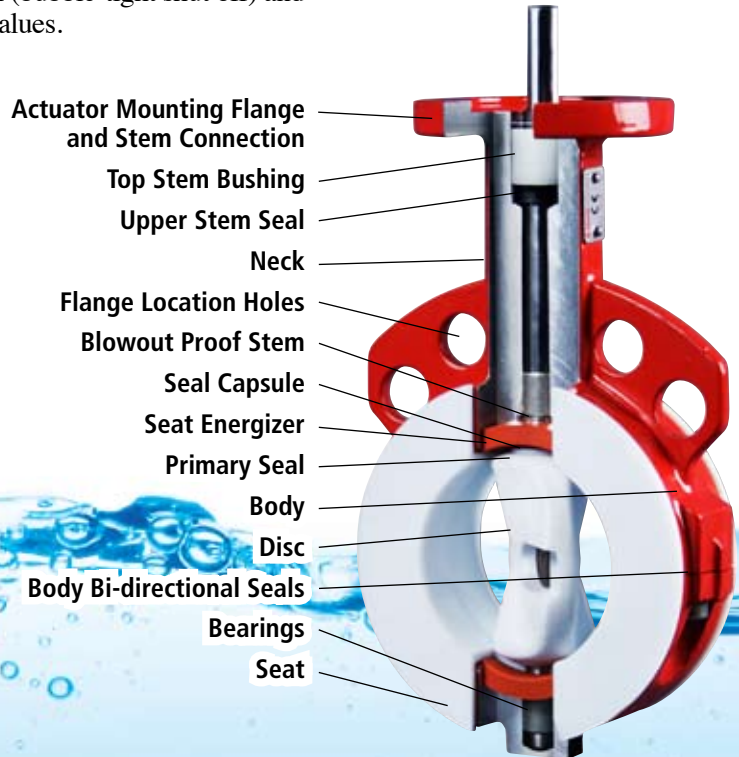

- Fully lined body and disc isolates all other valve parts from the media
- Thin disc profile dramatically reduces pressure drop/pump costs
- External polyester coating provides excellent corrosion and wear resistance
- Available with UHMWPE Trim
- Available for Sanitary and Ultra-Pure Water Requirements

# Actuators and Accessories

## Series 92/93 Pneumatic Actuators



**SERIES 63 3-WAY AND 4-WAY SOLENOID VALVES**



**SERIES 6A ELECTRO-PNEUMATIC POSITIONERS**

Bray's Series 92/93 line of high performance and high quality pneumatic actuators combines styling, strength, compactness and simplicity of design to produce the best rotary actuator in the market today.

Engineering excellence and precision manufacturing have produced a modular product line with reduced overall size requirements and economic savings. In addition, all Bray Accessories are fully modular and directly mount to the actuator – providing flexibility and efficiency at reduced cost.

**SPRING RETURN** Bray's Series 93 spring return models employ a unique cartridge system for easy conversion from direct acting to spring return actuation.



**SERIES 52 VALVE STATUS MONITORS**

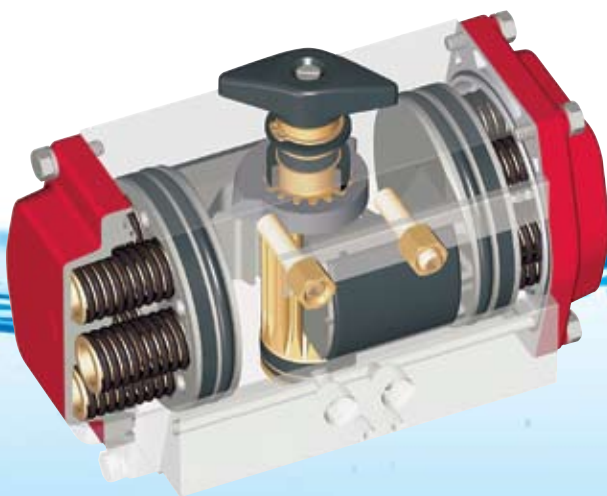

**SERIES 50 VALVE STATUS MONITORS**

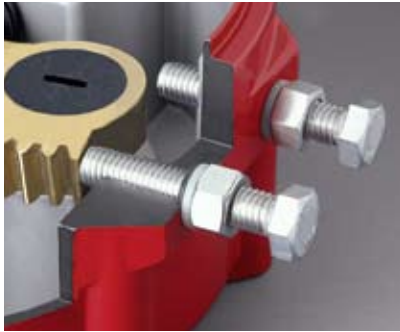

**STAINLESS STEEL  
MECHANICAL TRAVEL STOPS**



**INFINITELY ADJUSTABLE  
TRAVEL LIMIT CAMS**



**OPTIONAL TORQUE LIMITING  
SWITCH SYSTEM**



**SERVO OPERATION CAN  
BE CONFIGURED TO ACCEPT  
STANDARD INPUT SIGNALS**



## Series 70 Electric Actuators

### **RUGGED ELECTRIC ACTUATOR FOR ROTARY VALVES 300 LB-IN [34 Nm] TO 18,000 LB-IN [2030 Nm] OUTPUT TORQUE**

Bray Controls' years of proven success in electric actuation, combined with innovative engineering, has produced the Series 70. The Series 70 features on-off or modulating control. This electric actuator for rotary valves delivers highly reliable service.

Bray's unique Control Center has many advantages over present industry standards including:

- UL, CSA and CE certification available
- Ease of customer field wiring directly to the terminal strip without interference from other components
- Simple and unique manual override handwheel system
- Lowest profile and lightest weight actuator on the market
- Simple finger or screw driver infinite adjustment of travel limit cams without interference from other components
- Highly visible valve status indicator
- Externally adjustable travel stops
- Captive cover bolts
- Components not requiring customer access are protected underneath the Power Center cover plate.

### **SEACORR COATING AVAILABLE FOR CORROSIVE ENVIRONMENTS**

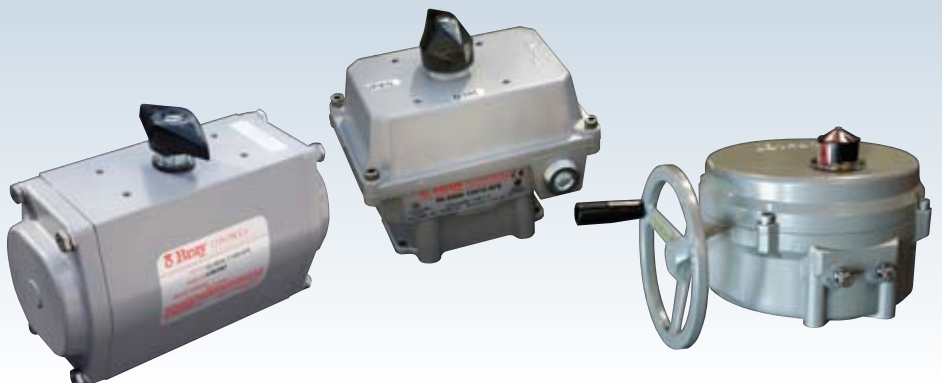



**Bray International - Houston, Texas**



**Bray China**



**Flow-Tek - Houston, Texas**



**Bray Canada**



**Bray United Kingdom**



**Flow-Tek China**



**Bray Mexico**



**Bray Brazil**



**Bray Benelux**



**Bray Pacific  
(Australia)**



**Bray Chile**



**RitePro Canada**



**Bray Germany**



**Bray Poland**

All statements, technical information, and recommendations in this bulletin are for general use only. Consult Bray representatives or factory for the specific requirements and material selection for your intended application. The right to change or modify product design or product without prior notice is reserved.

United States patent number 5,152,501.

Other patents issued and applied for worldwide.



A Division of BRAY INTERNATIONAL, Inc.  
13333 Westland East Blvd. Houston, Texas 77041  
281.894.5454 FAX 281.894.9499 www.bray.com